

# 施行地区位置図

S=1/2,500



吉田病院

北中振丁目

枚方中振郵便局

市道出口北中振1号線

国道1号

市道中振新香里線

光善寺駅

府道八尾枚方線

さだ生涯学習市民センター

老人福祉センター  
楽寿荘

凡例



施行区域

0 50 100m

# 施行地区位置図

S=1/4,000



## 凡例



施行区域

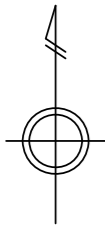

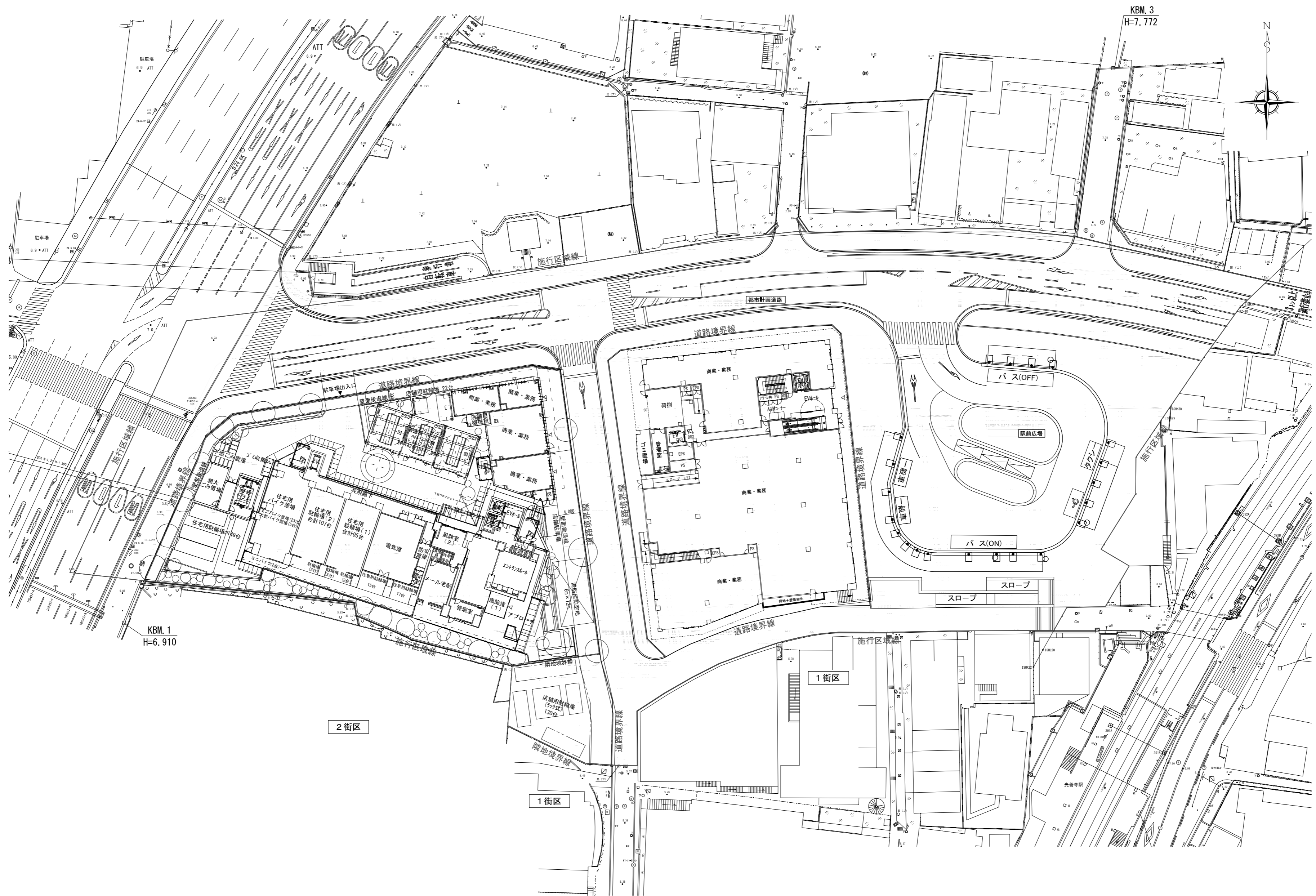

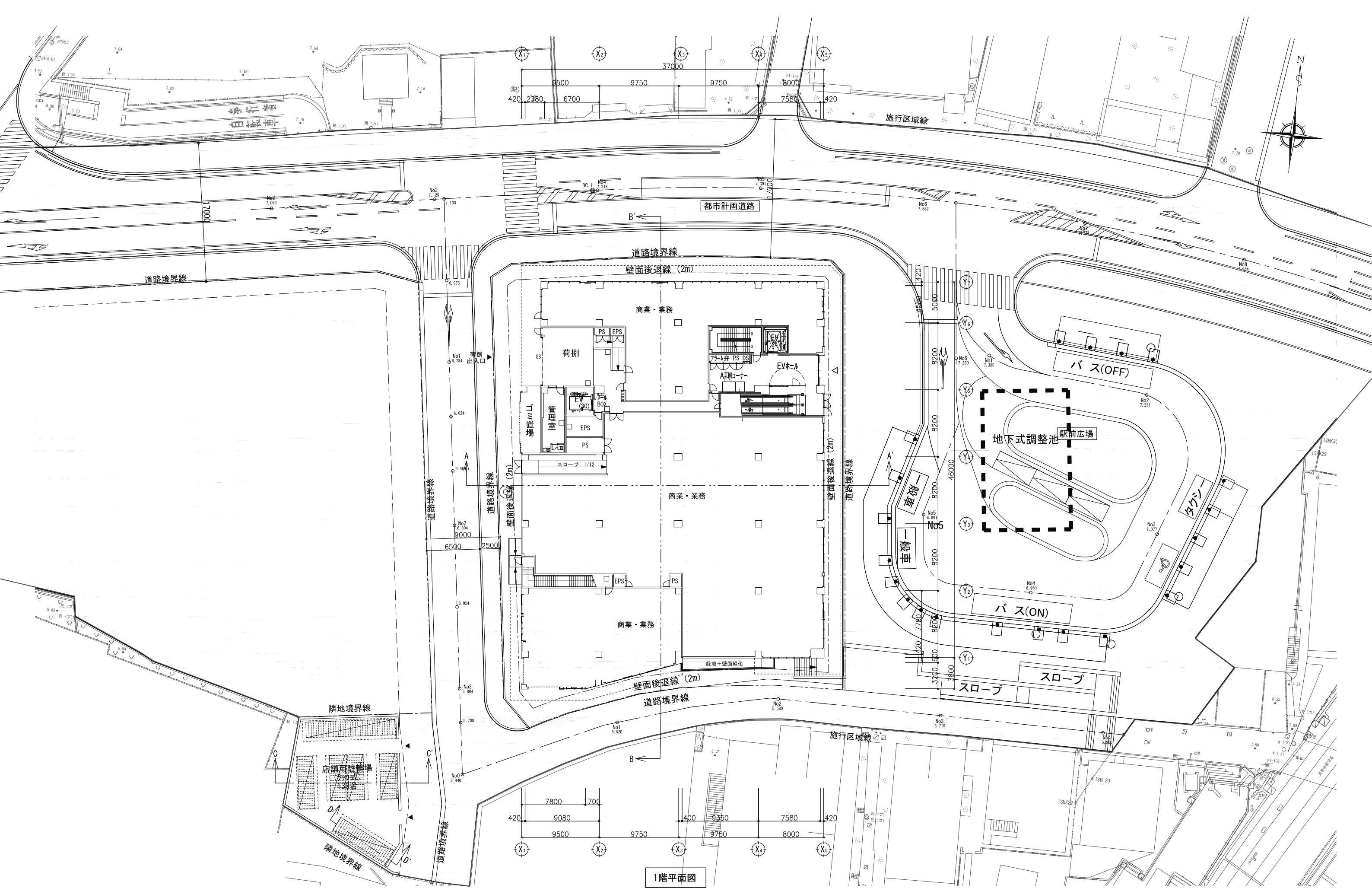

1階平面図

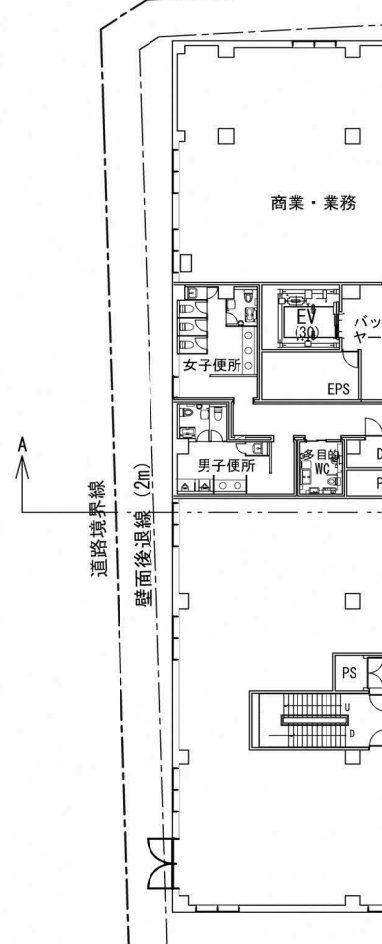
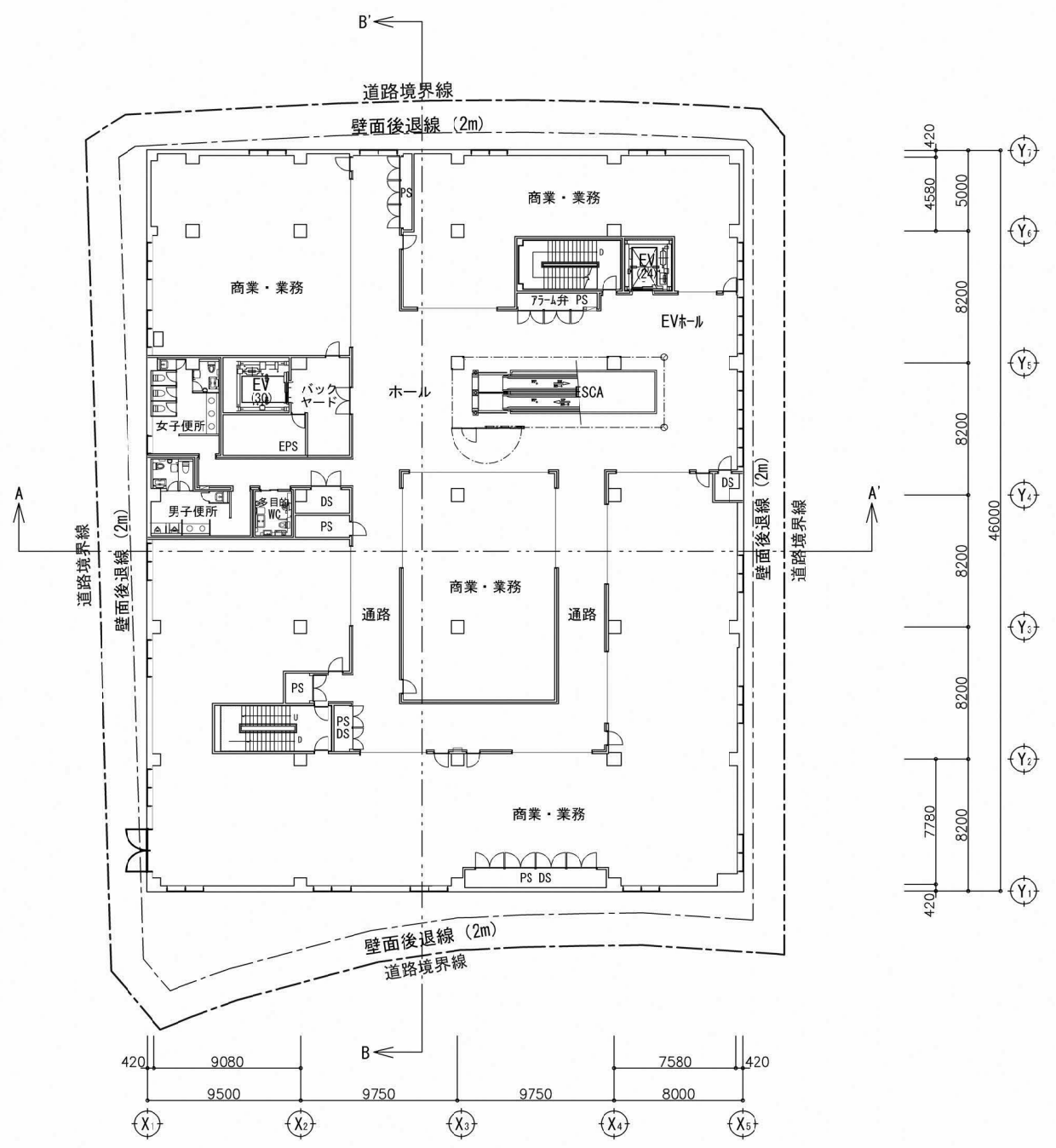
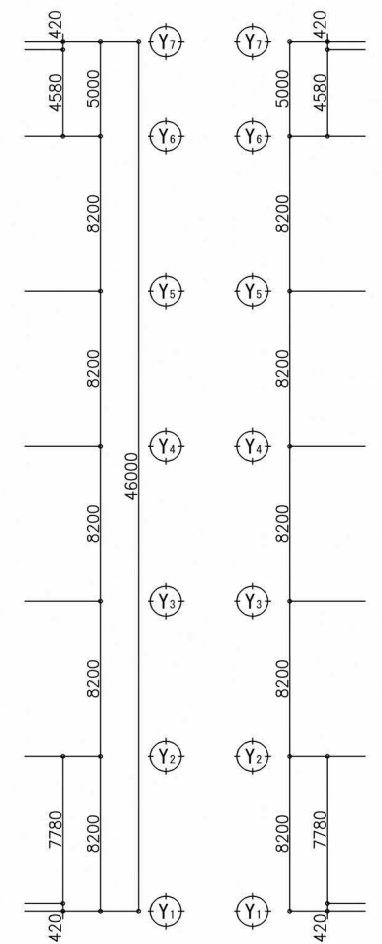
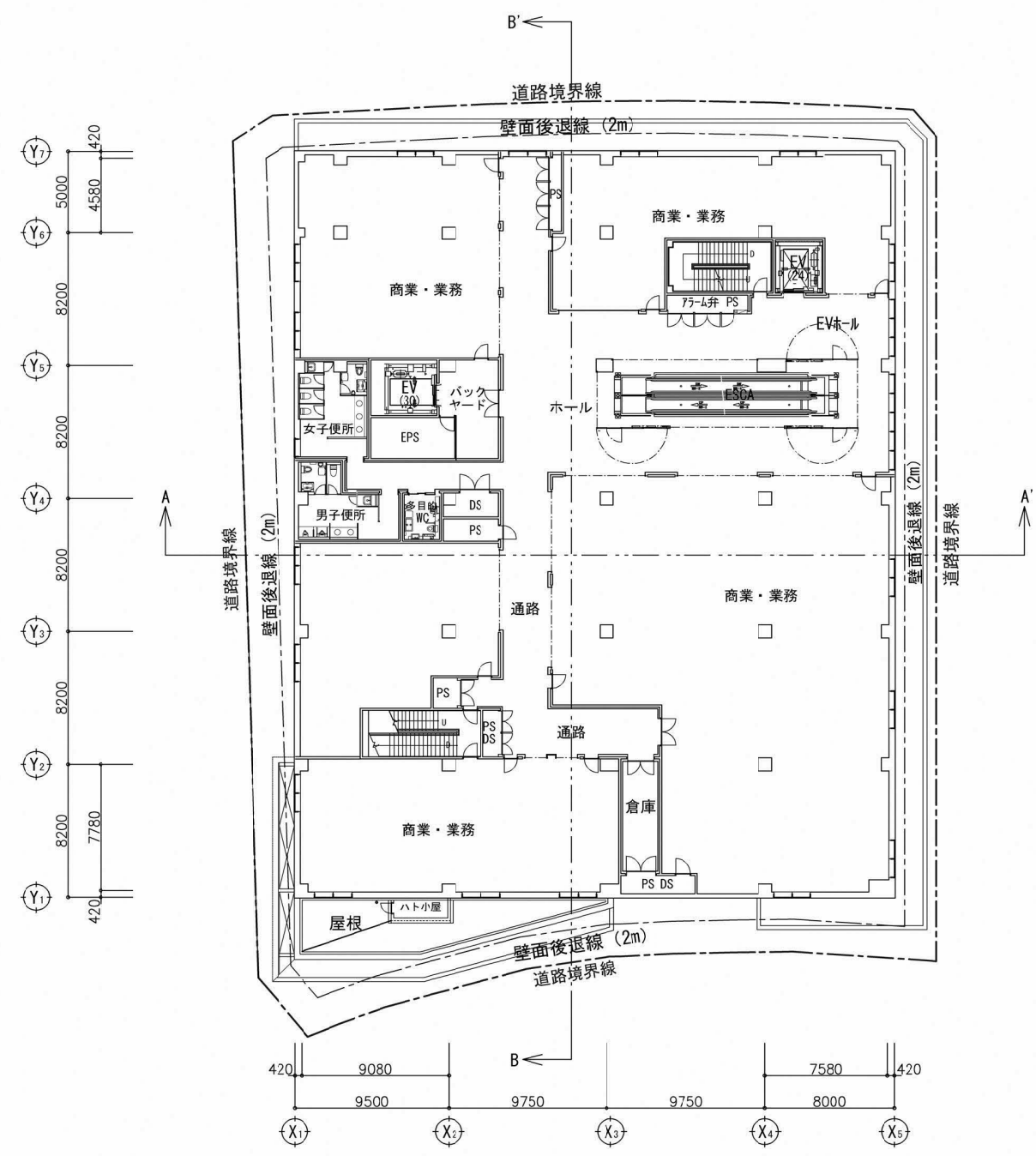
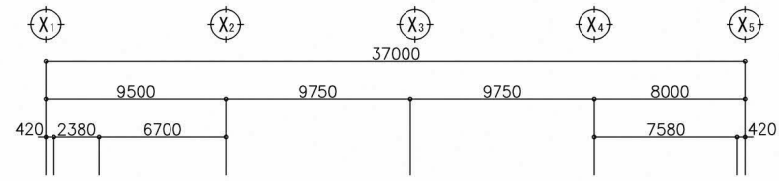
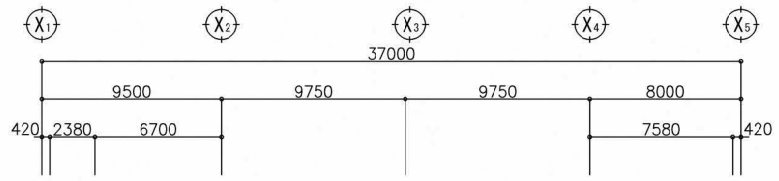
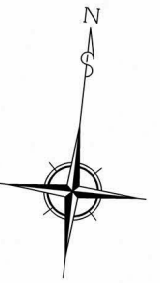

2階平面図

3階平面図

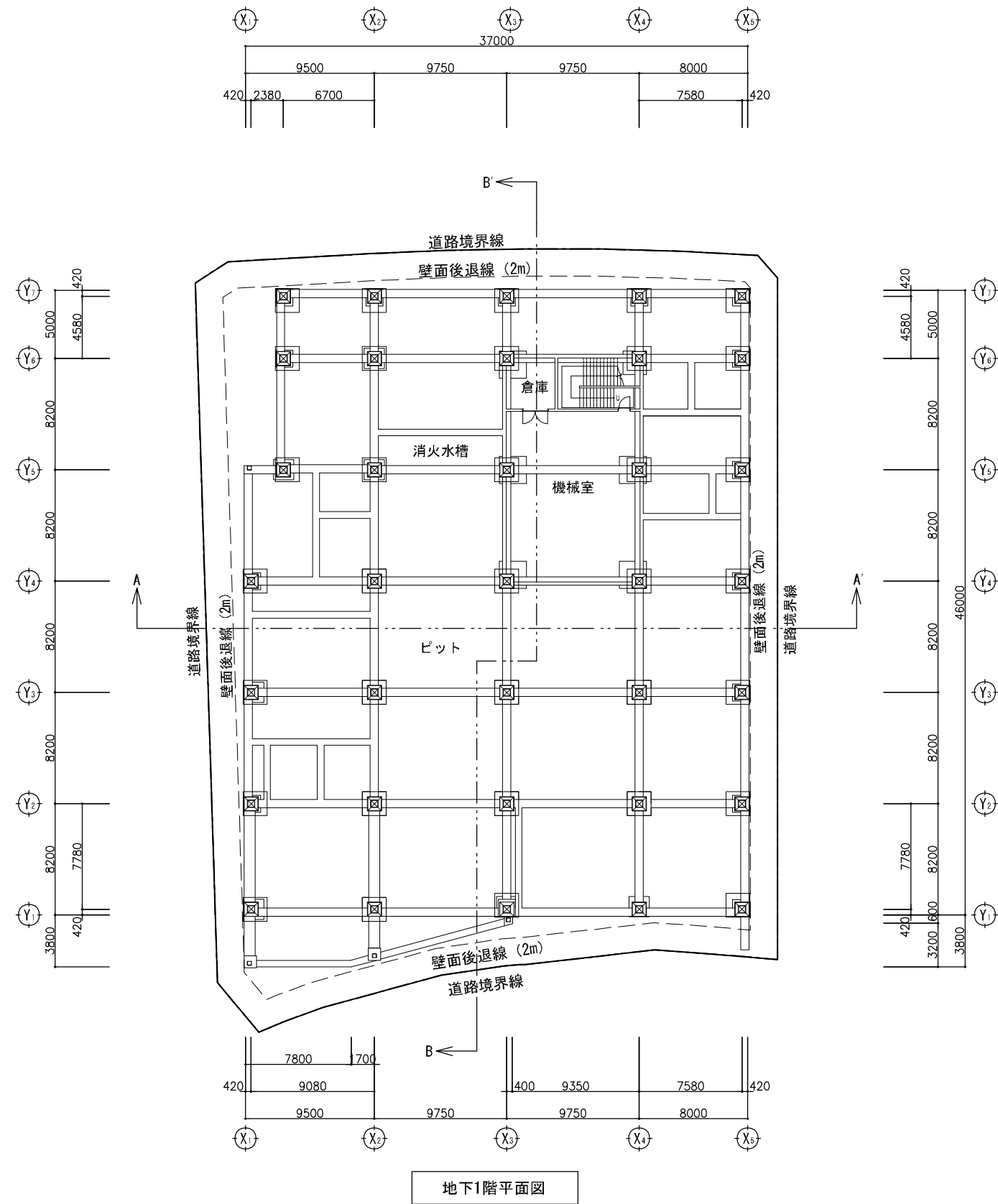
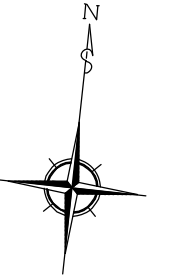

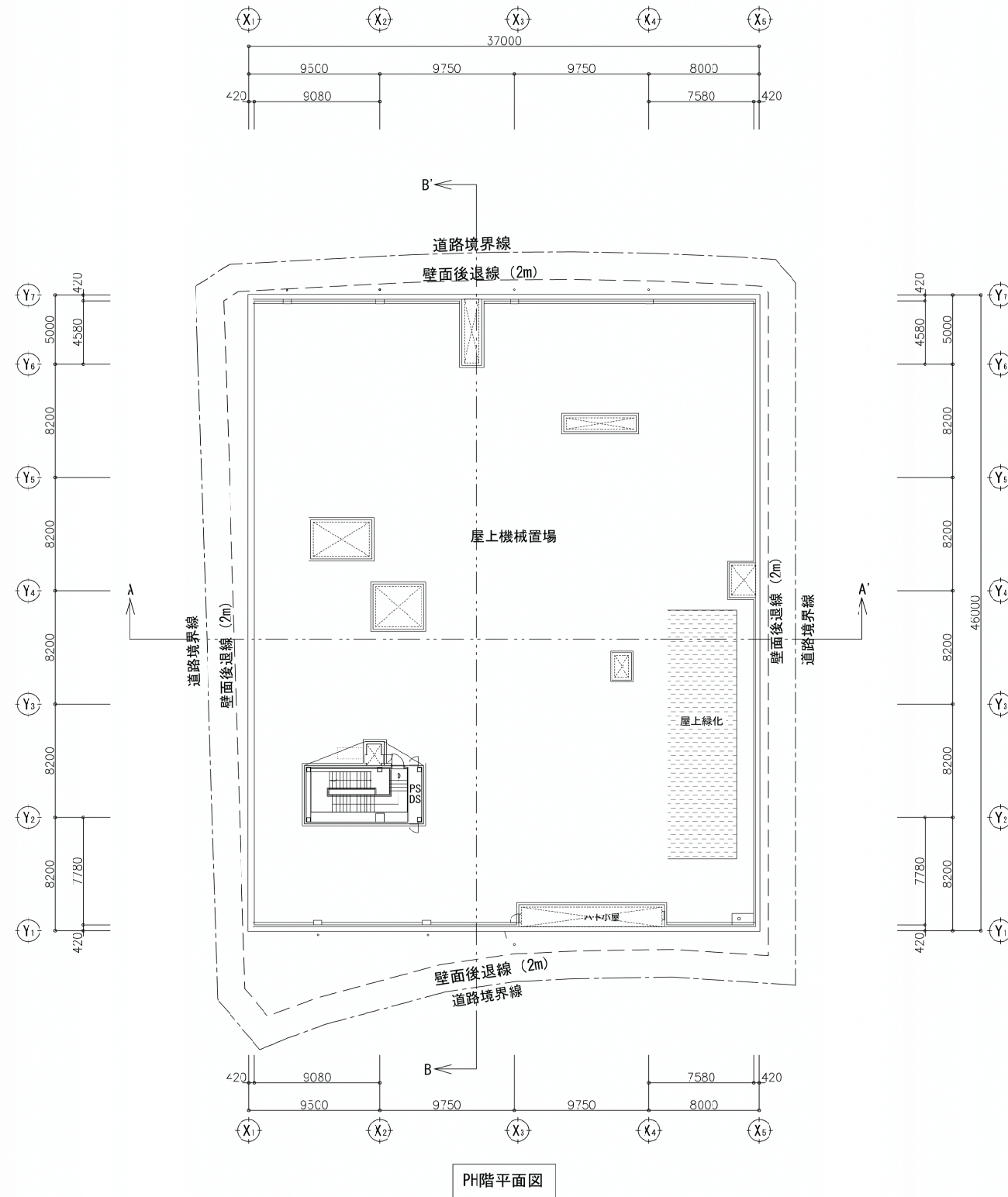
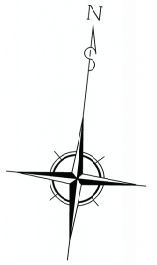



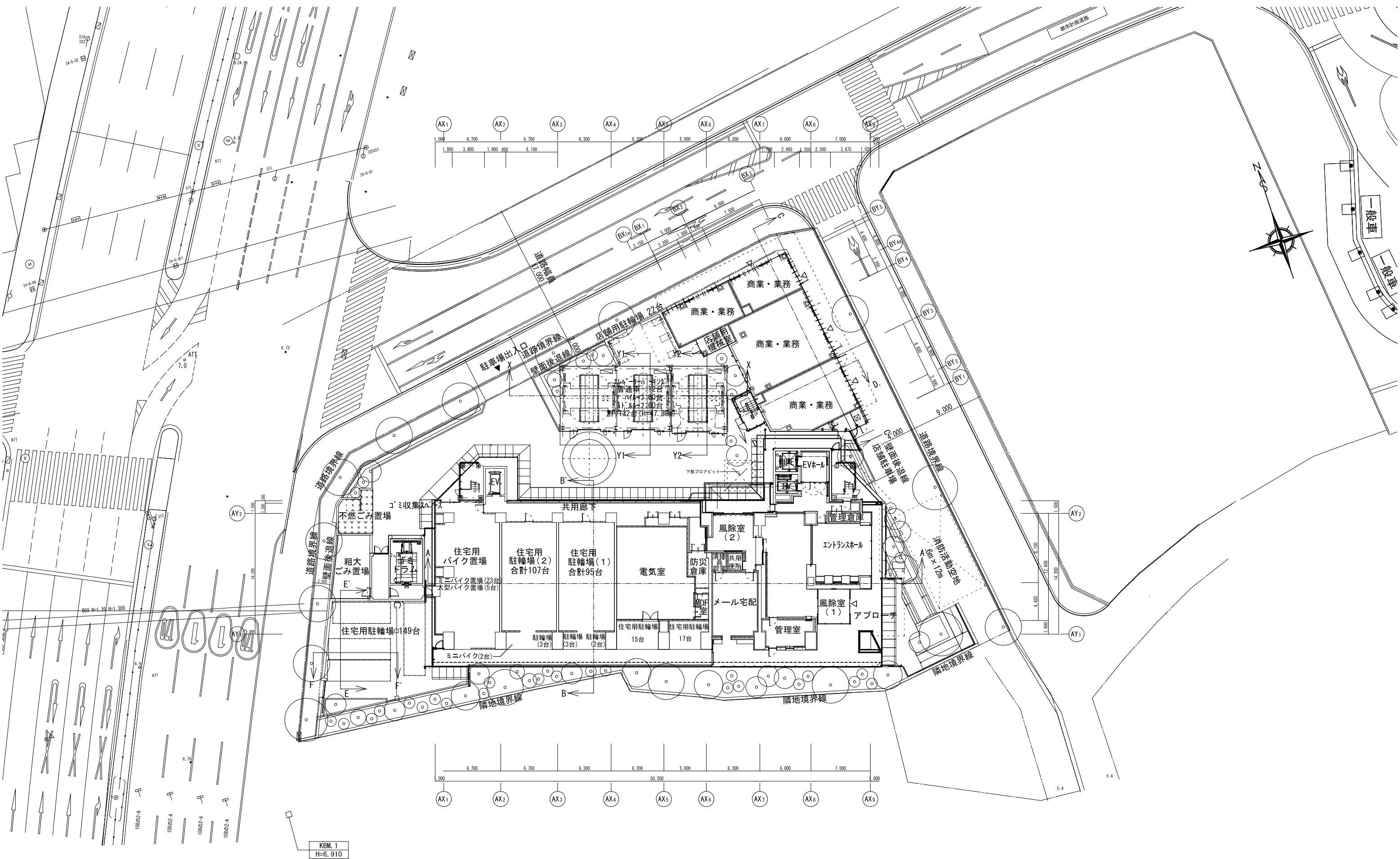

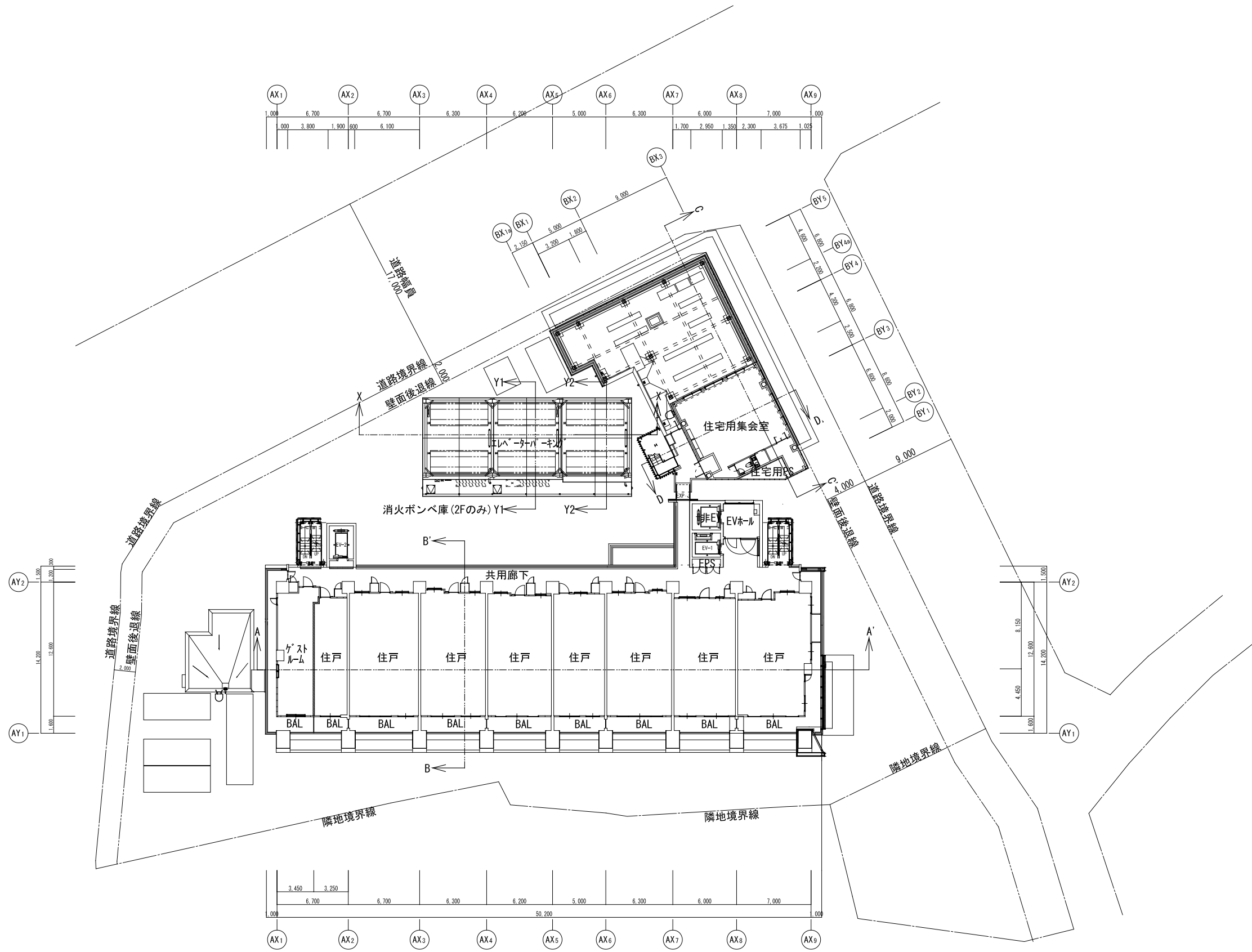

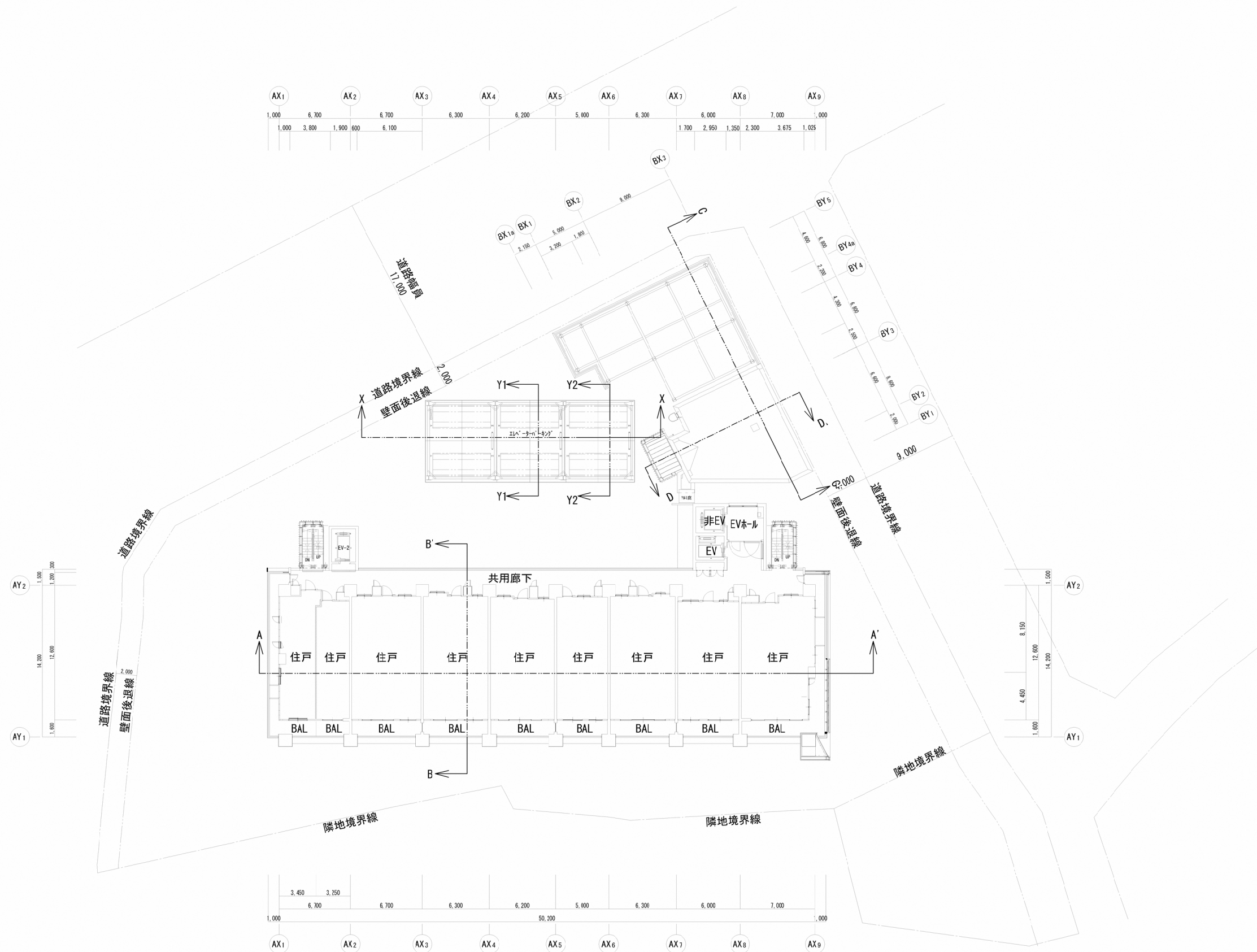

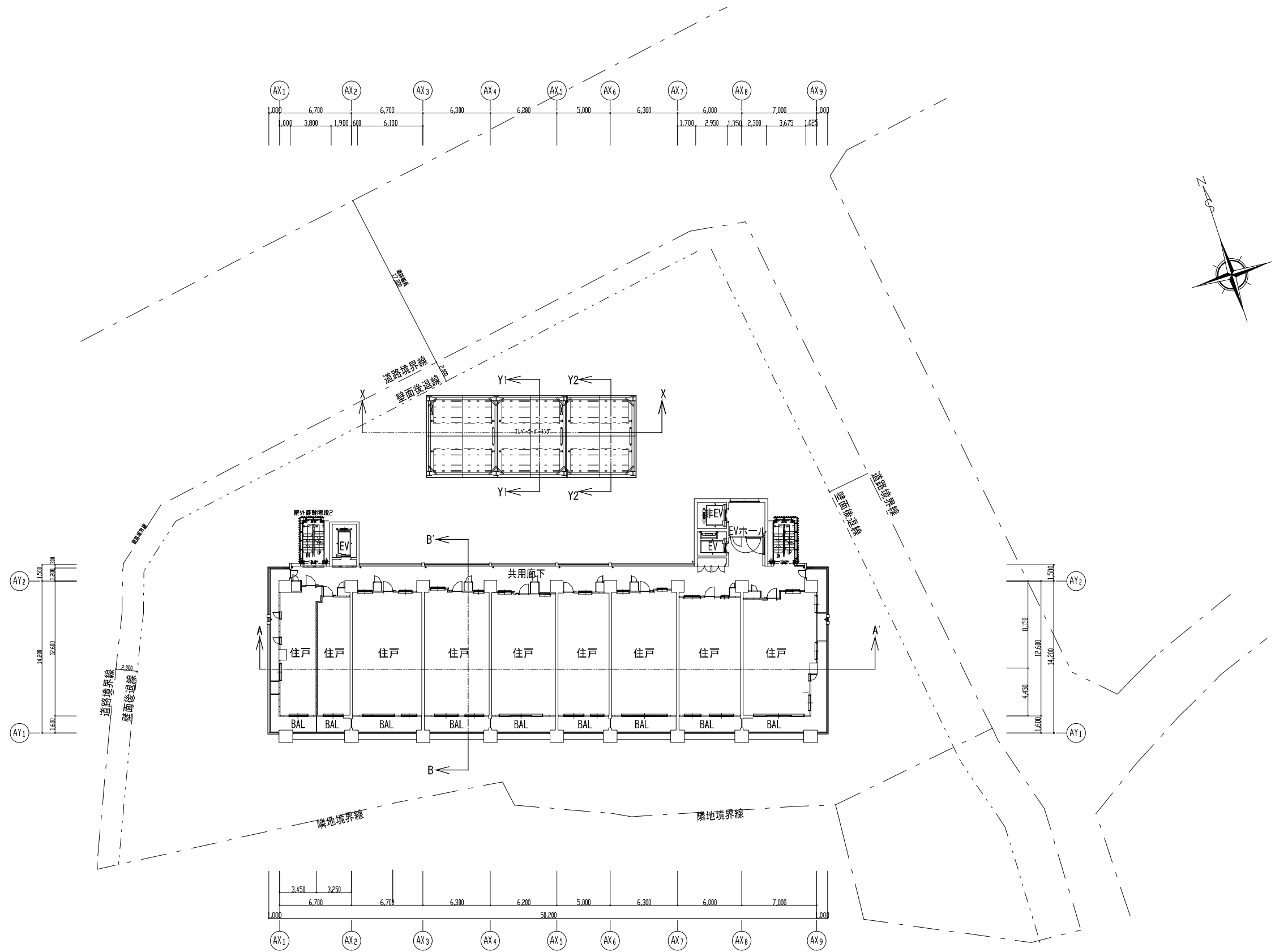

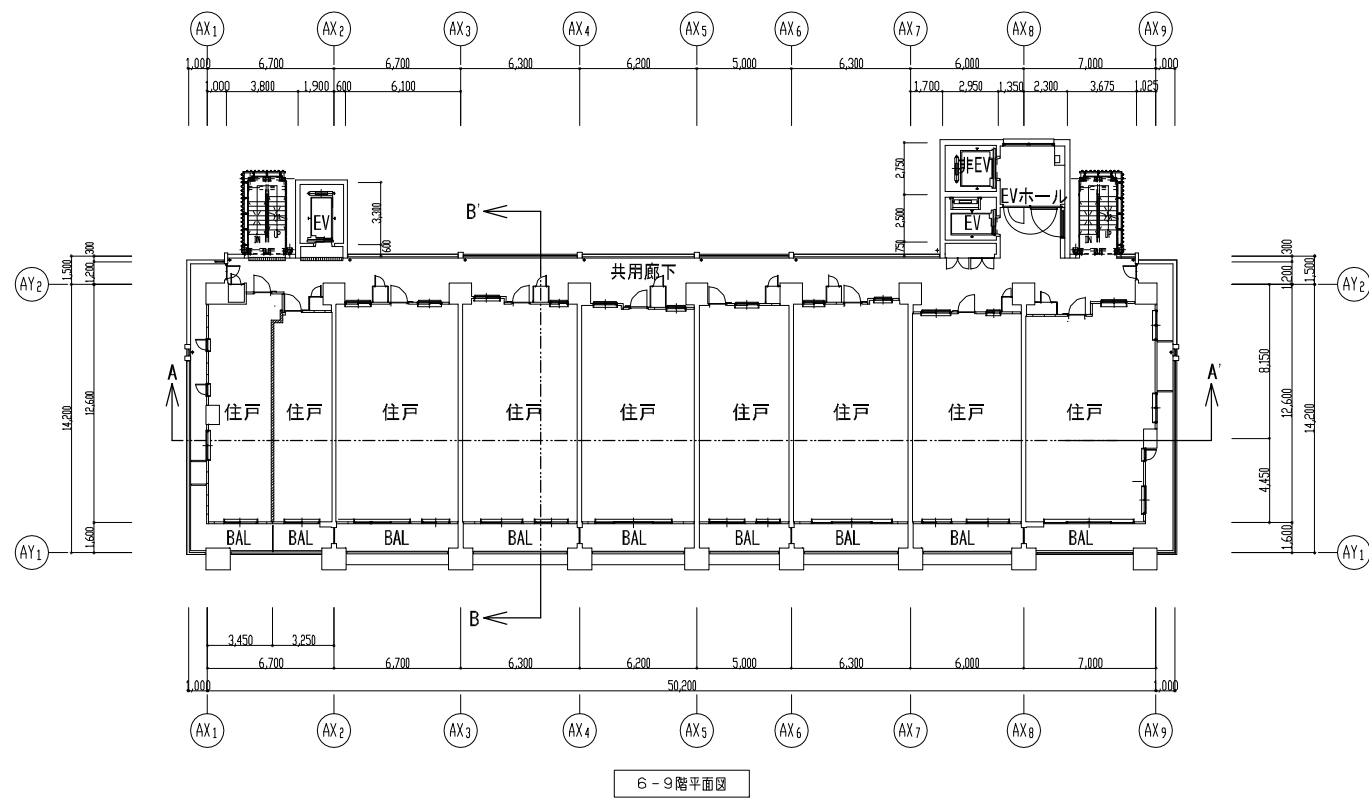

6-9階平面図

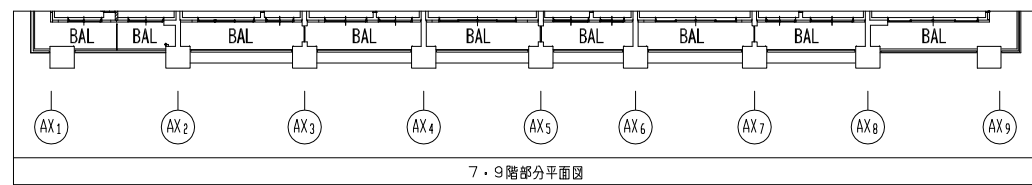

7-9階部分平面図

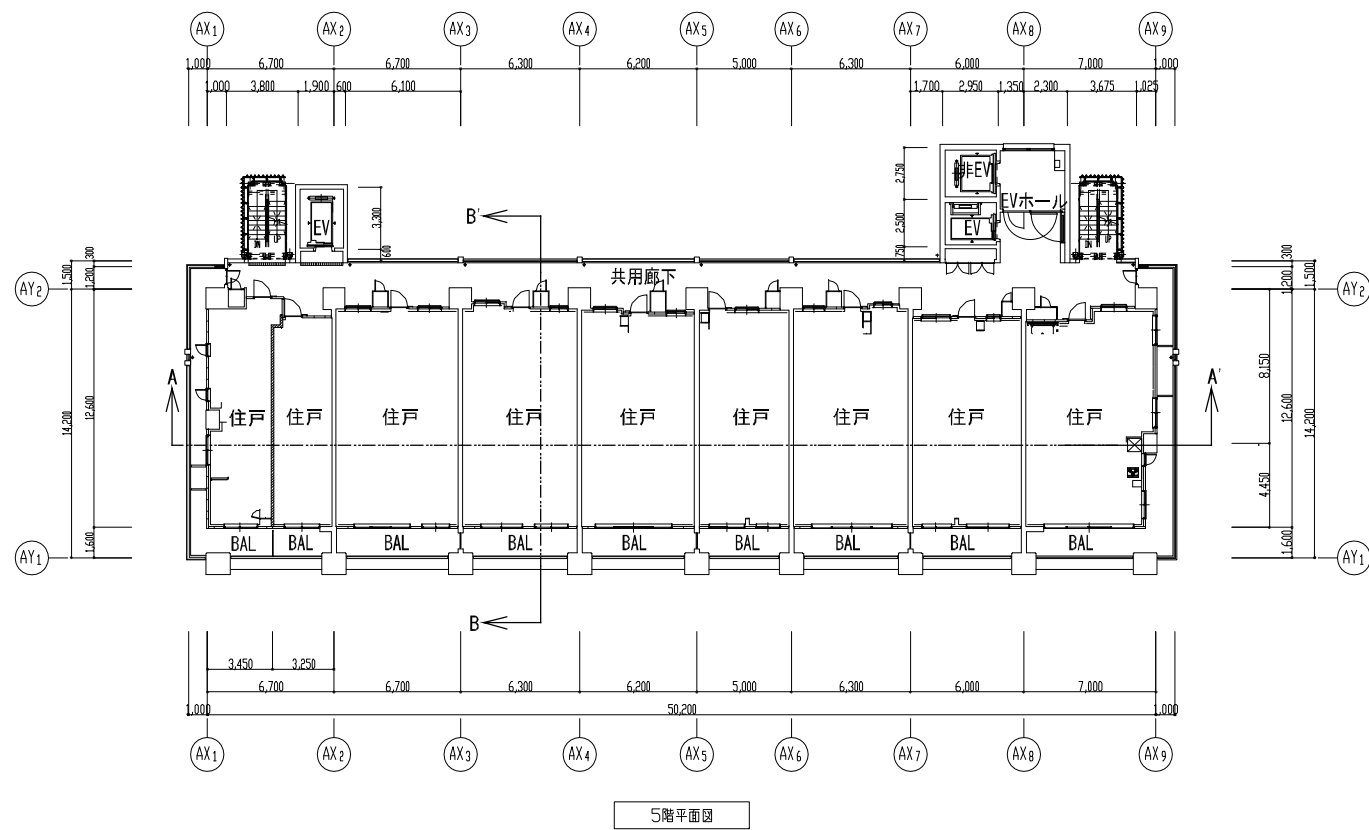

5階平面図

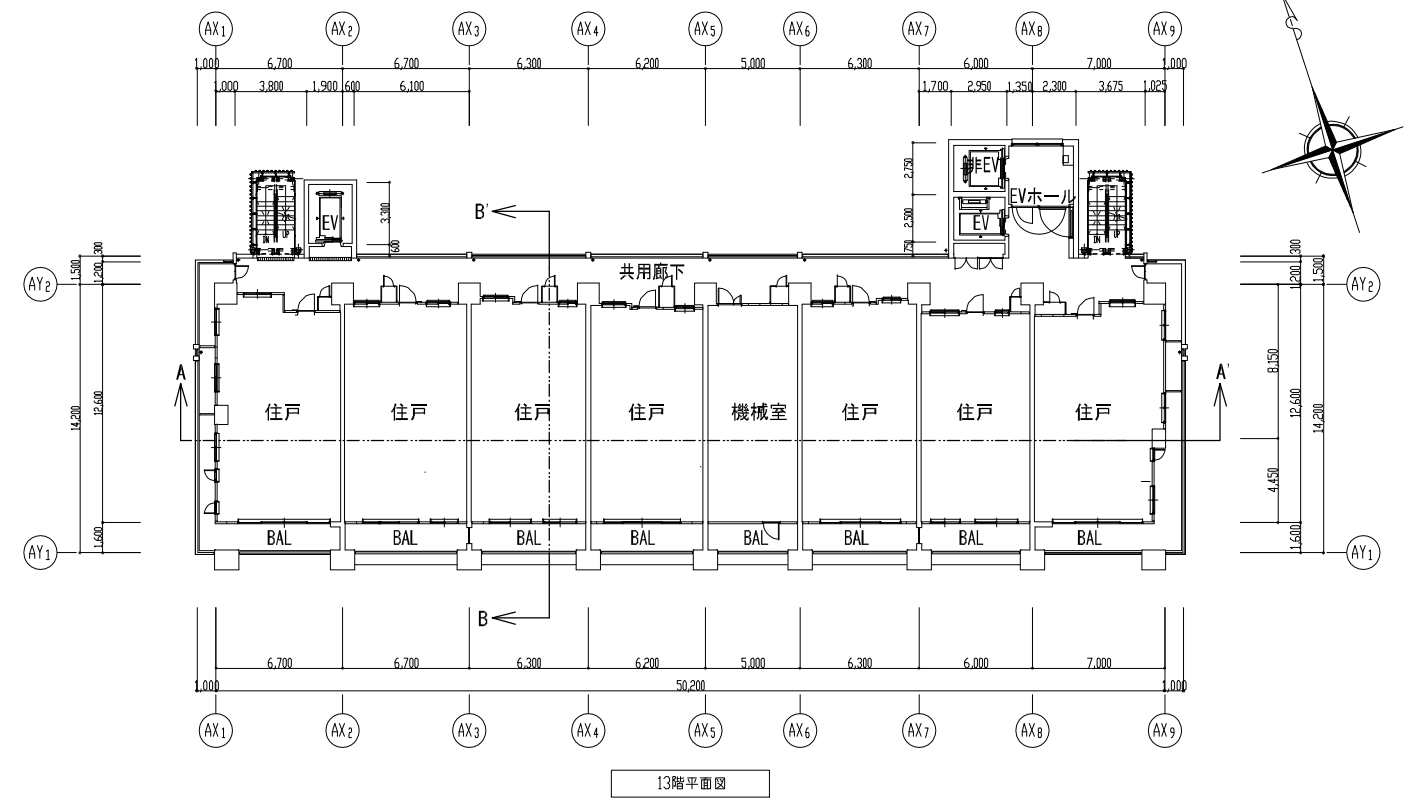

13階平面図

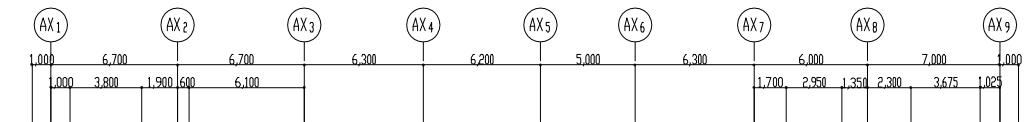

10-12・14階平面図

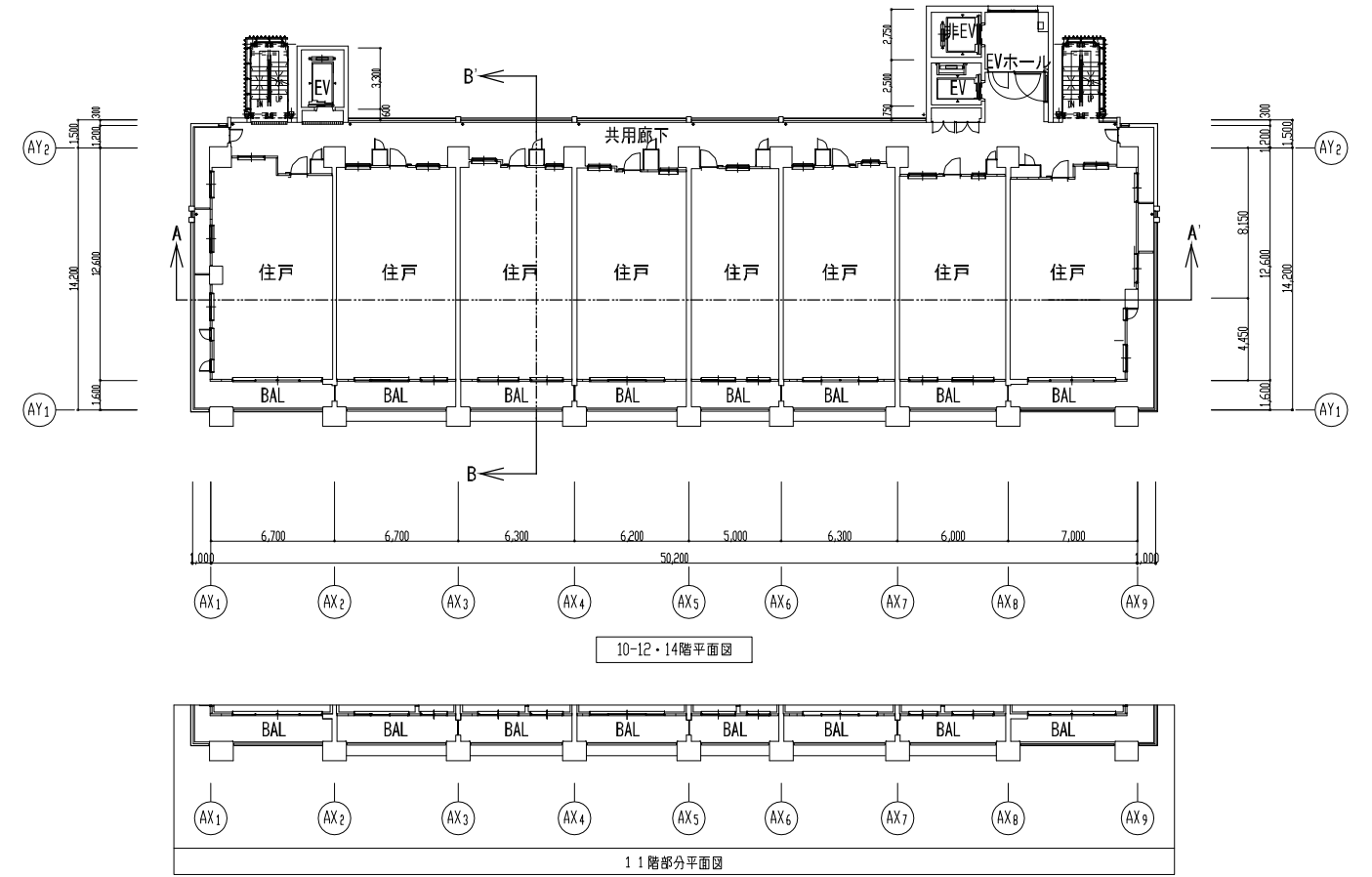

11階部分平面図

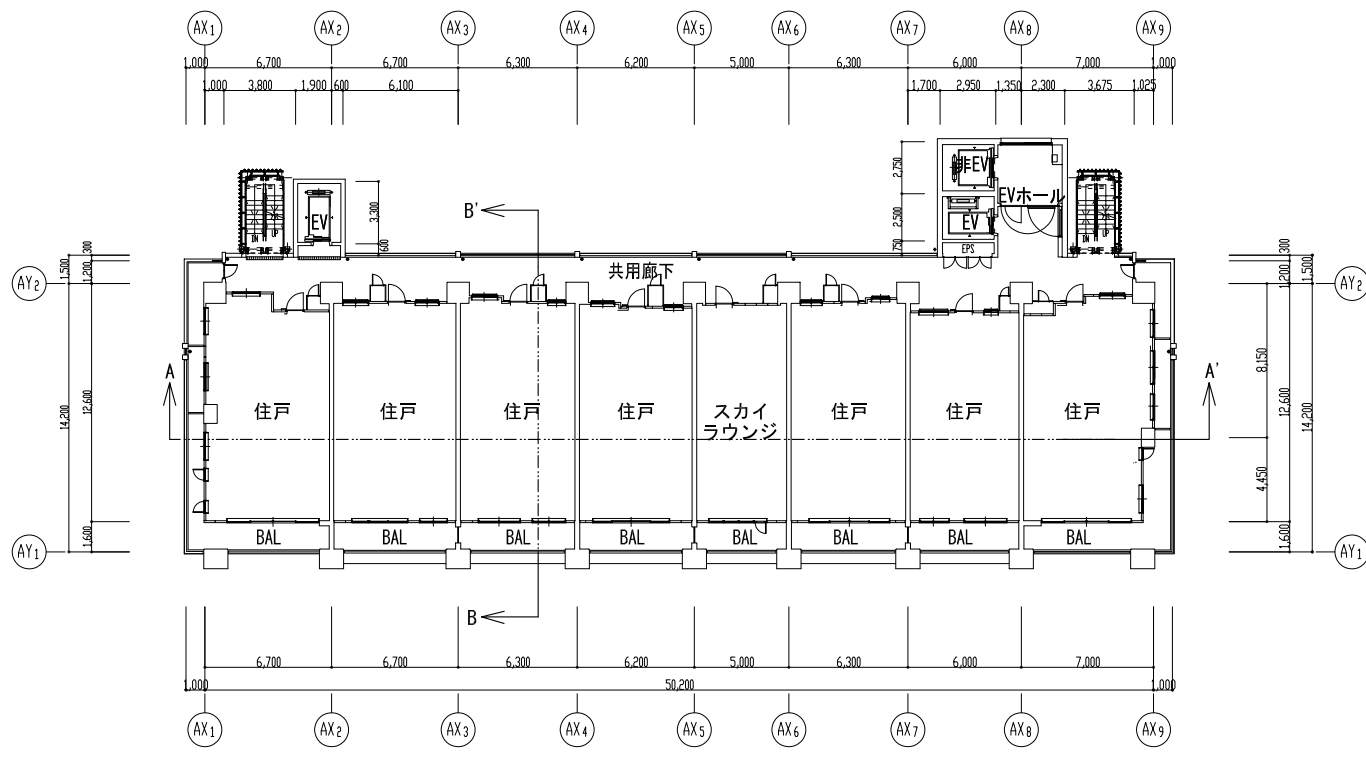

19階平面図

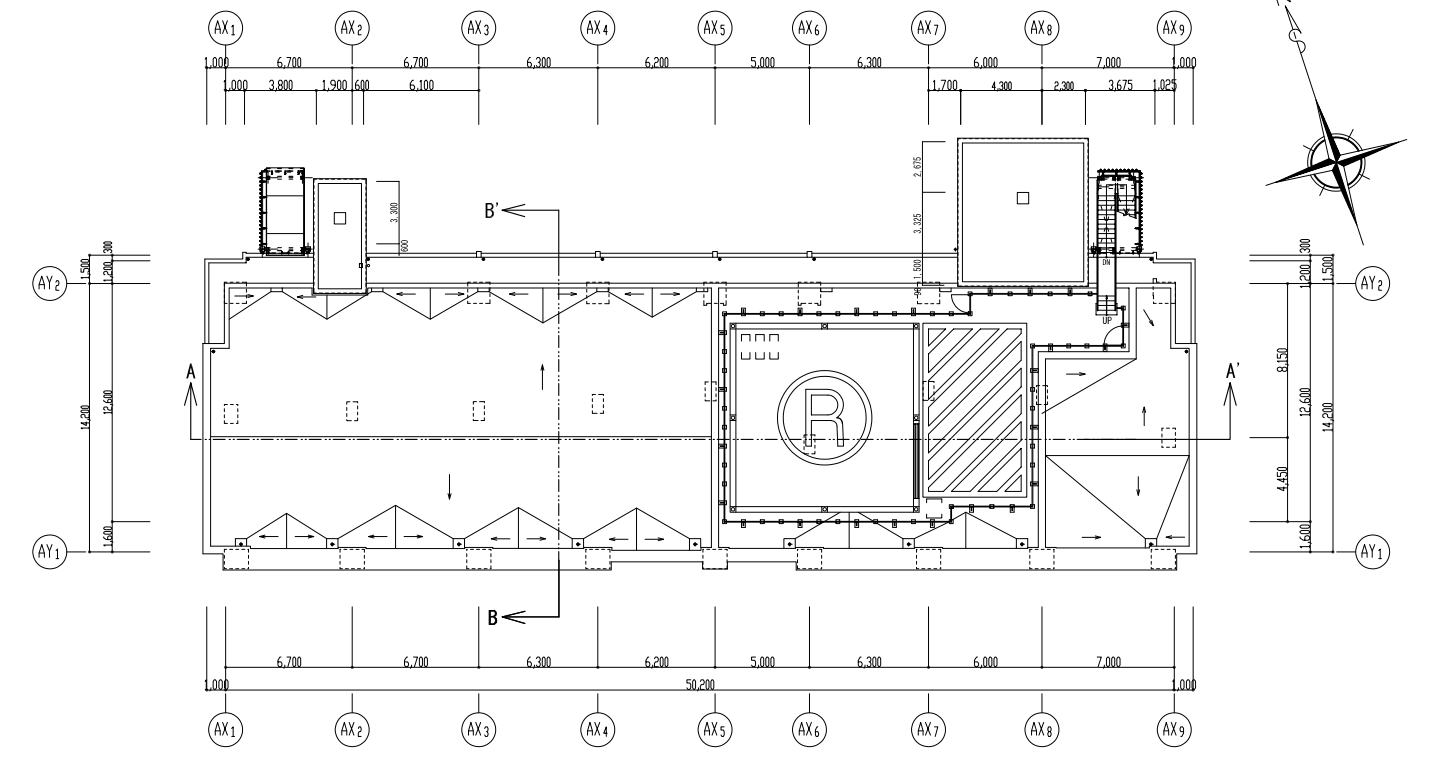

R階平面図

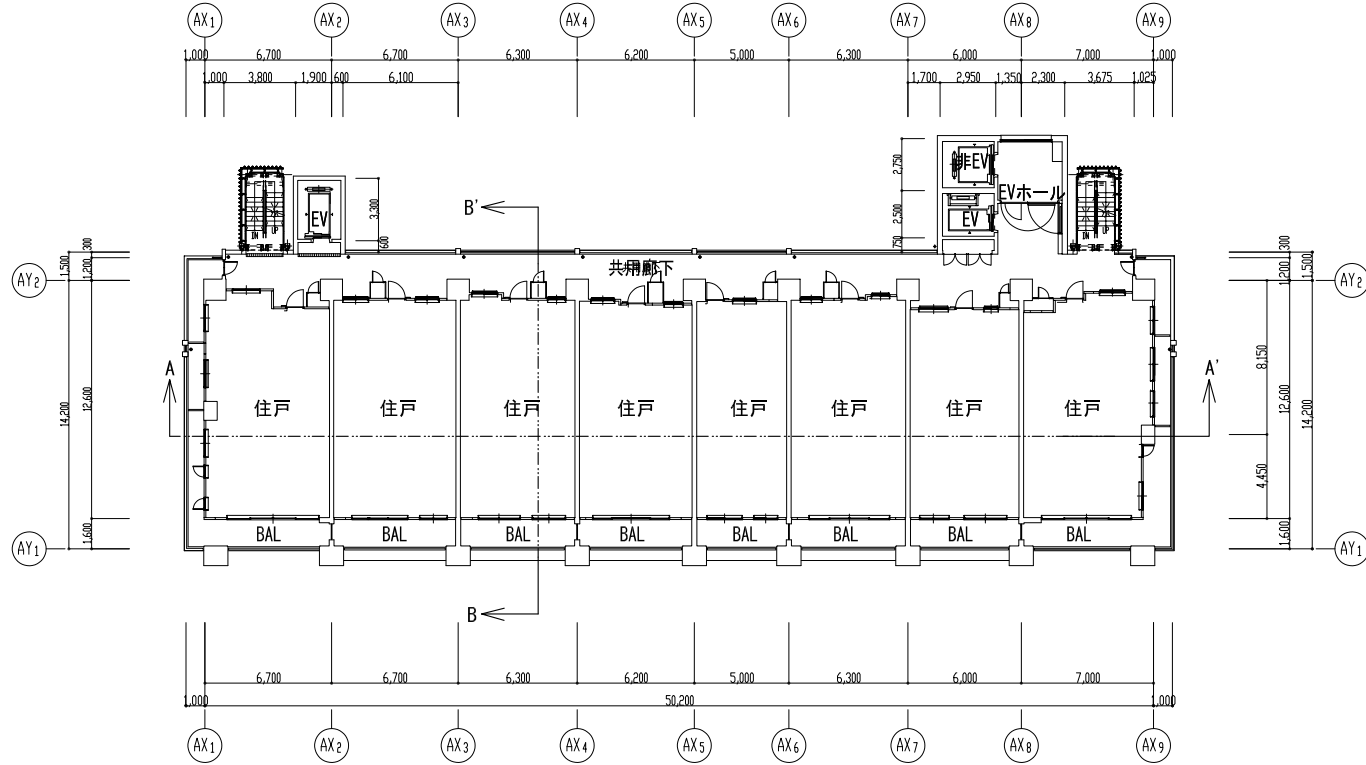

15-18・20-25階平面図

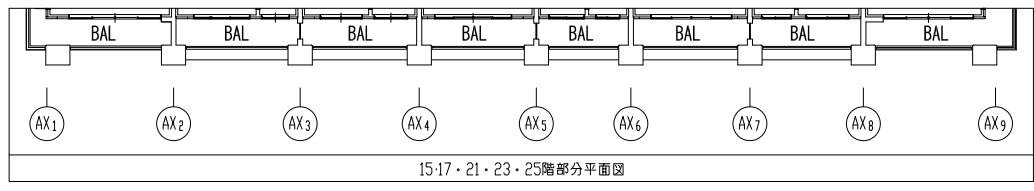

15-17・21・23・25階部分平面図

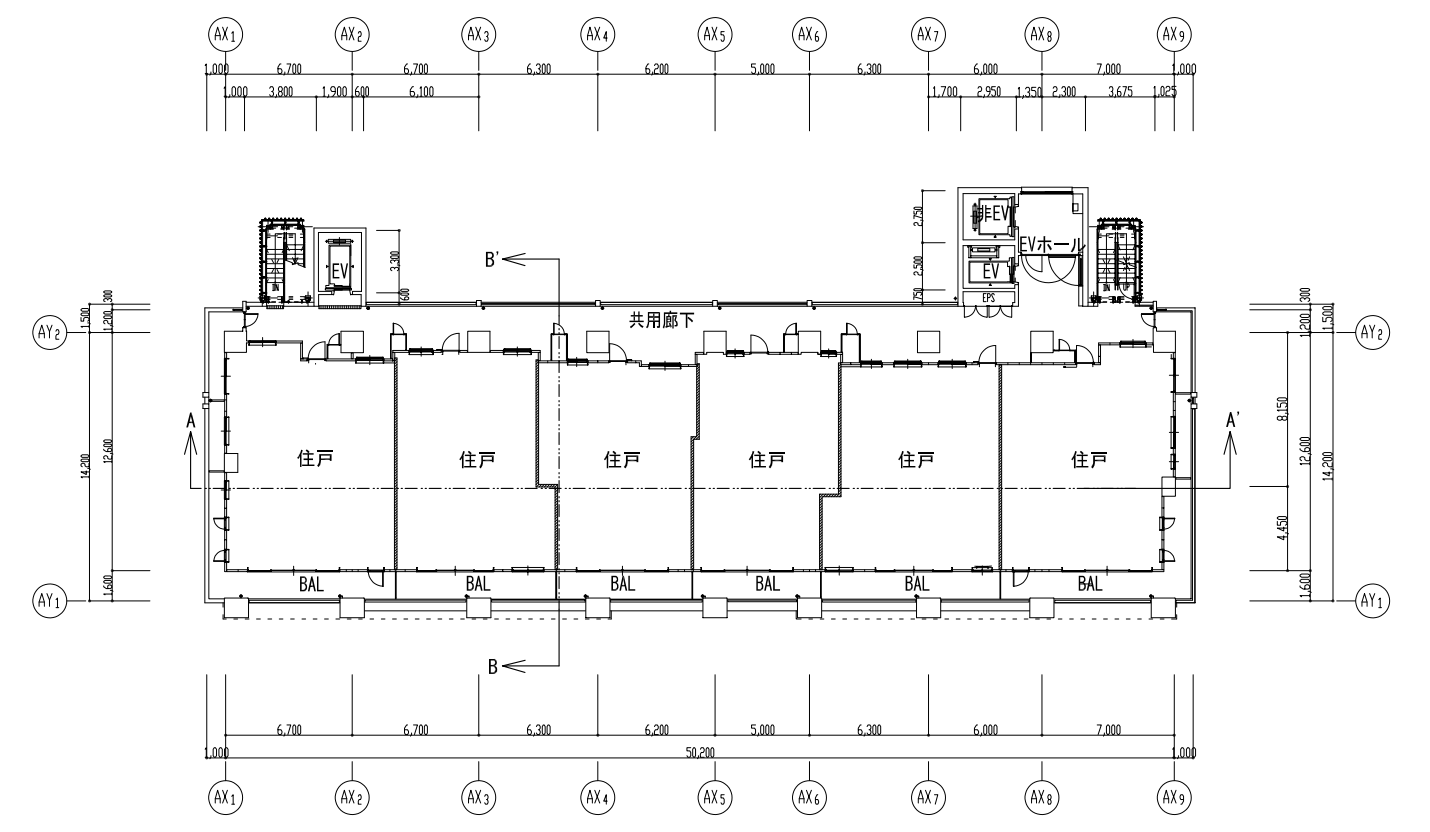

26階平面図

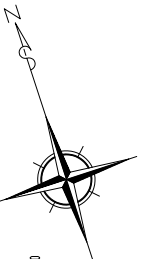

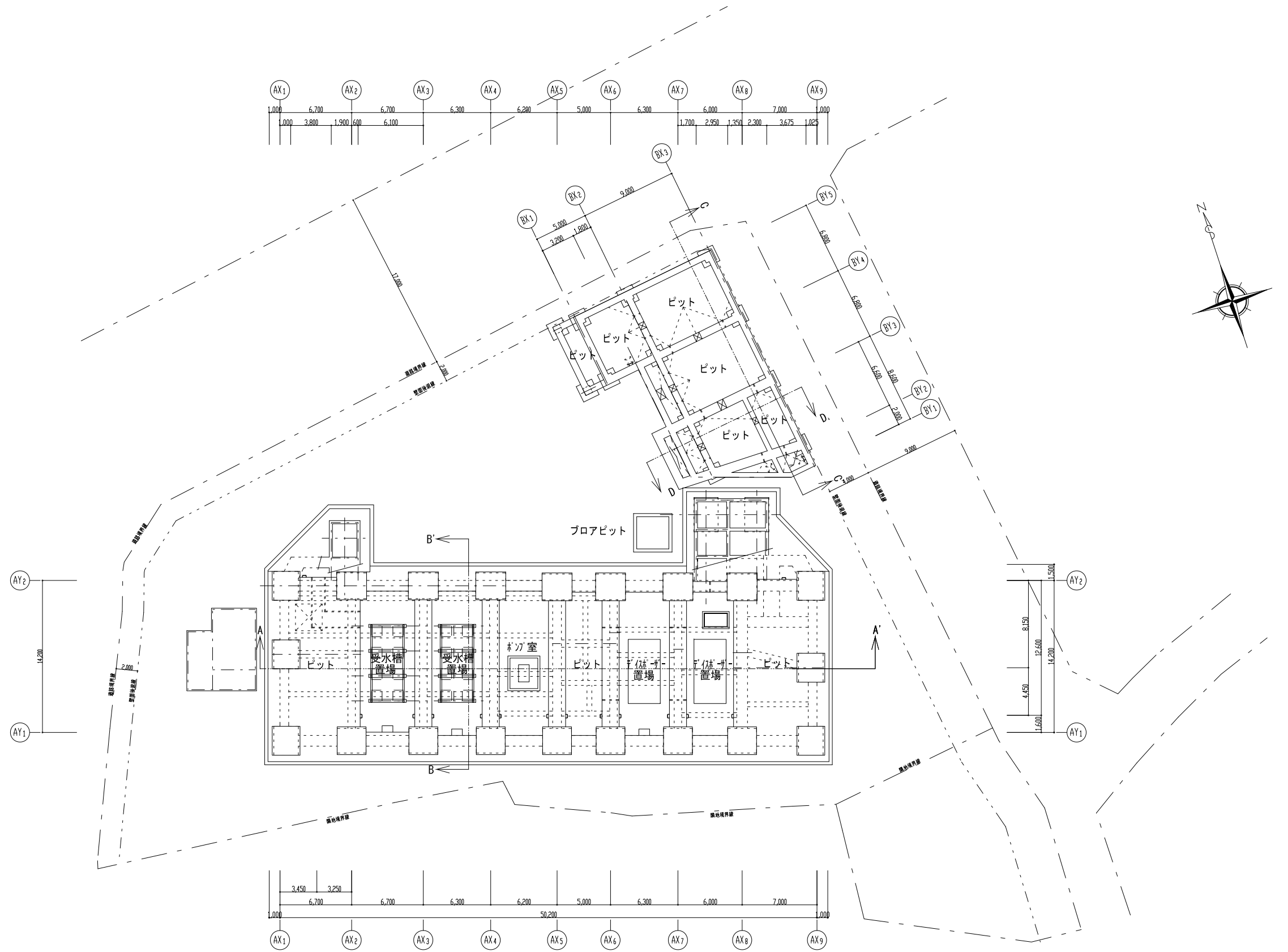

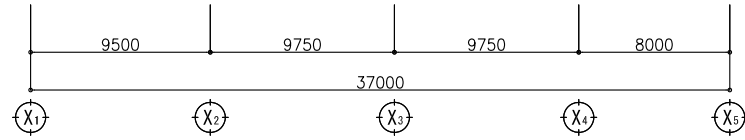
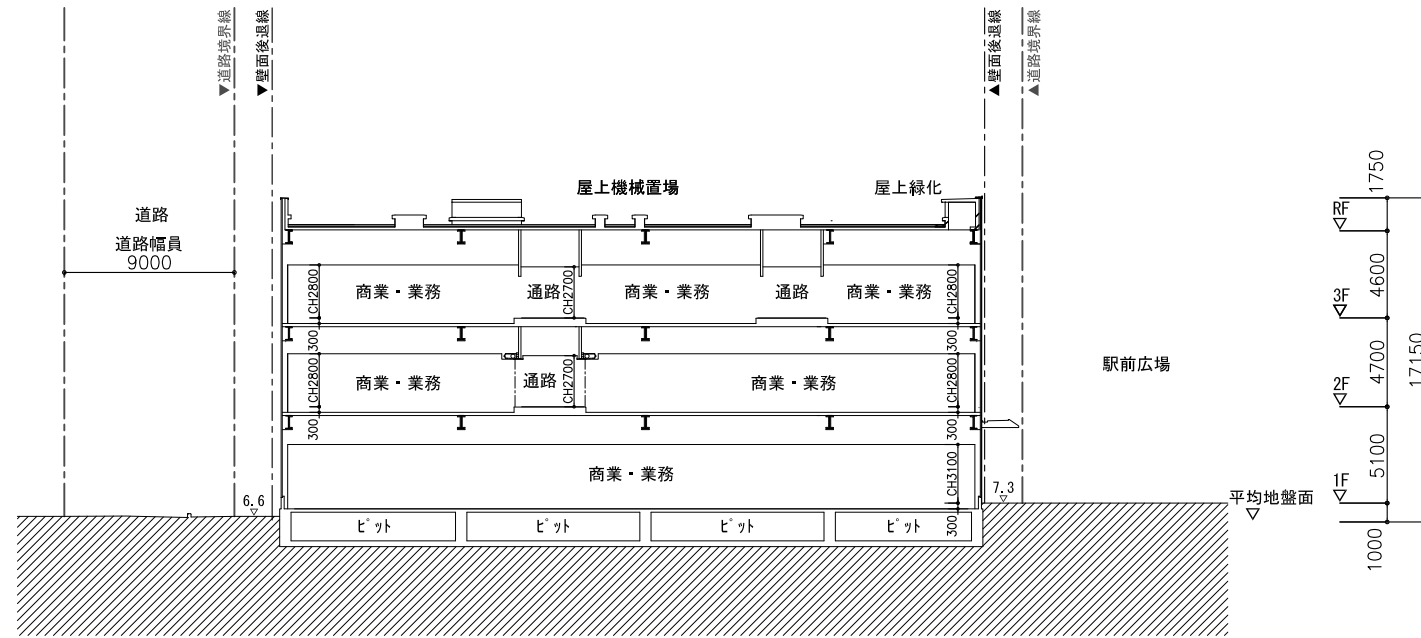

1街区 A-A' 断面図

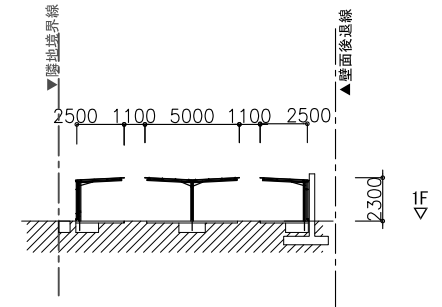

1街区 C-C' 断面図

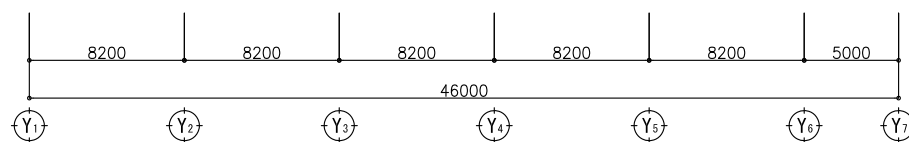
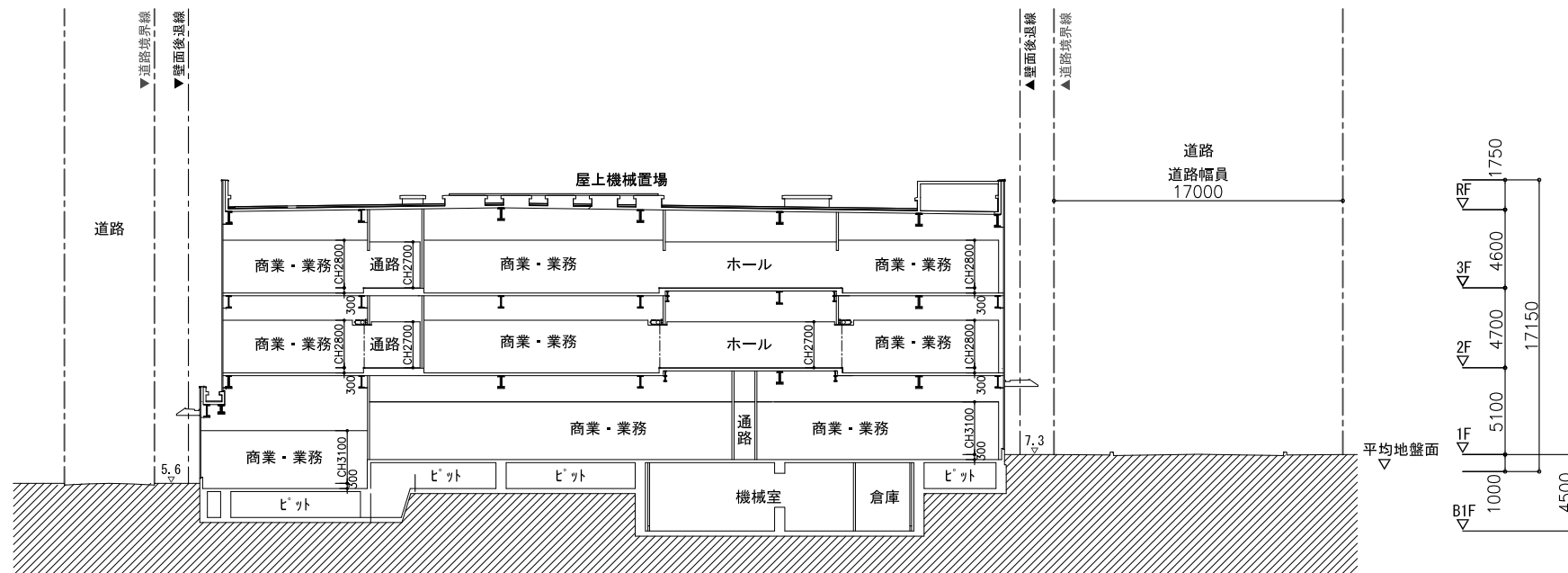

1街区 B-B' 断面図

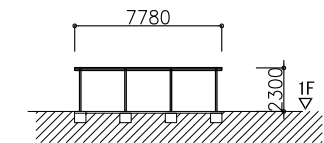

1街区 D-D' 断面図



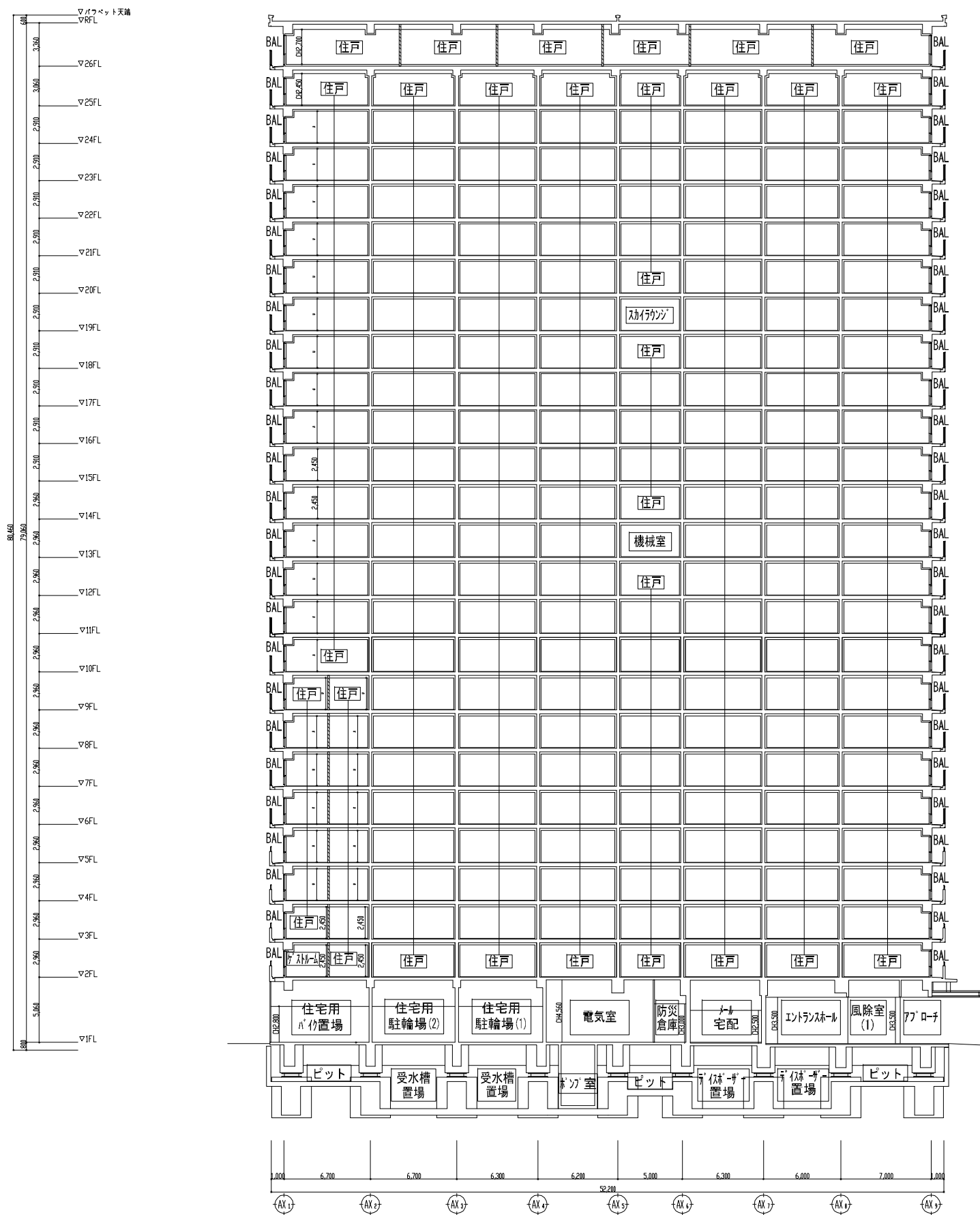

2街区 A-A' 断面図

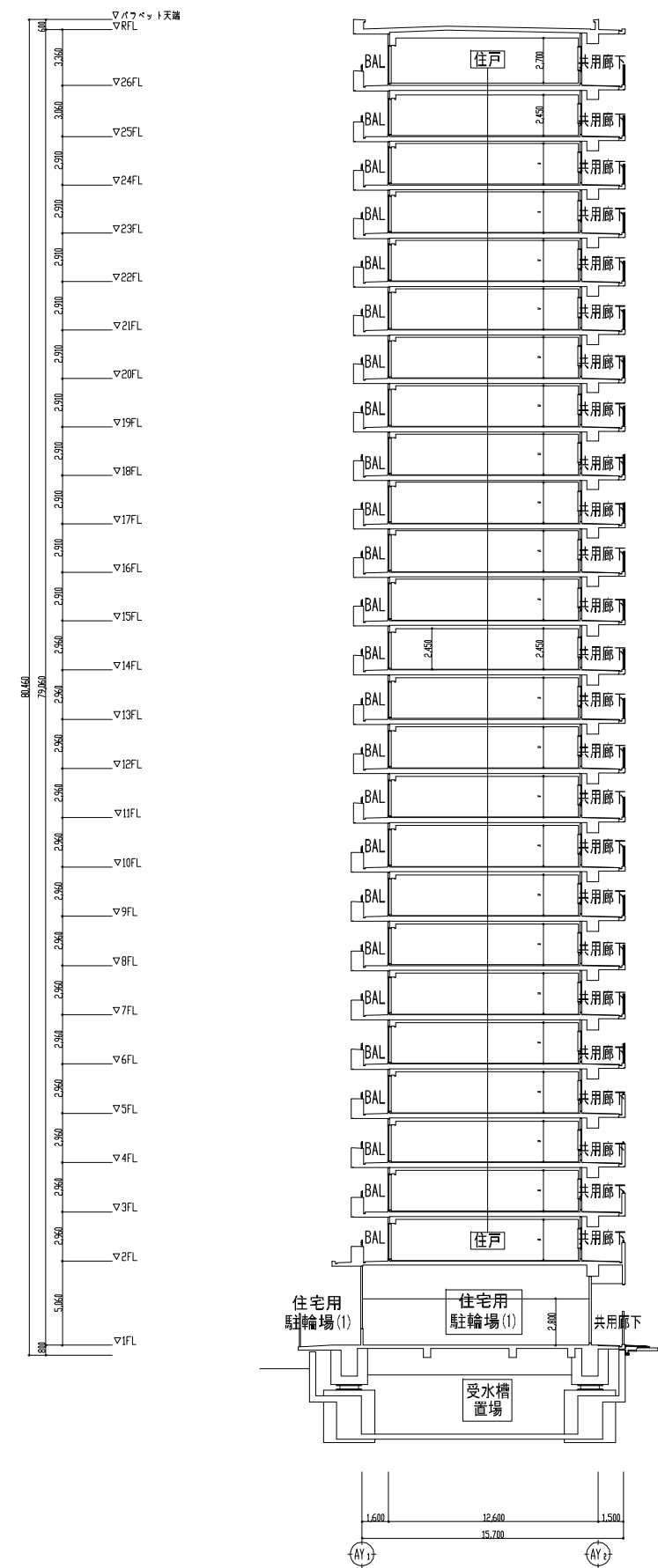

2街区 B-B' 断面図

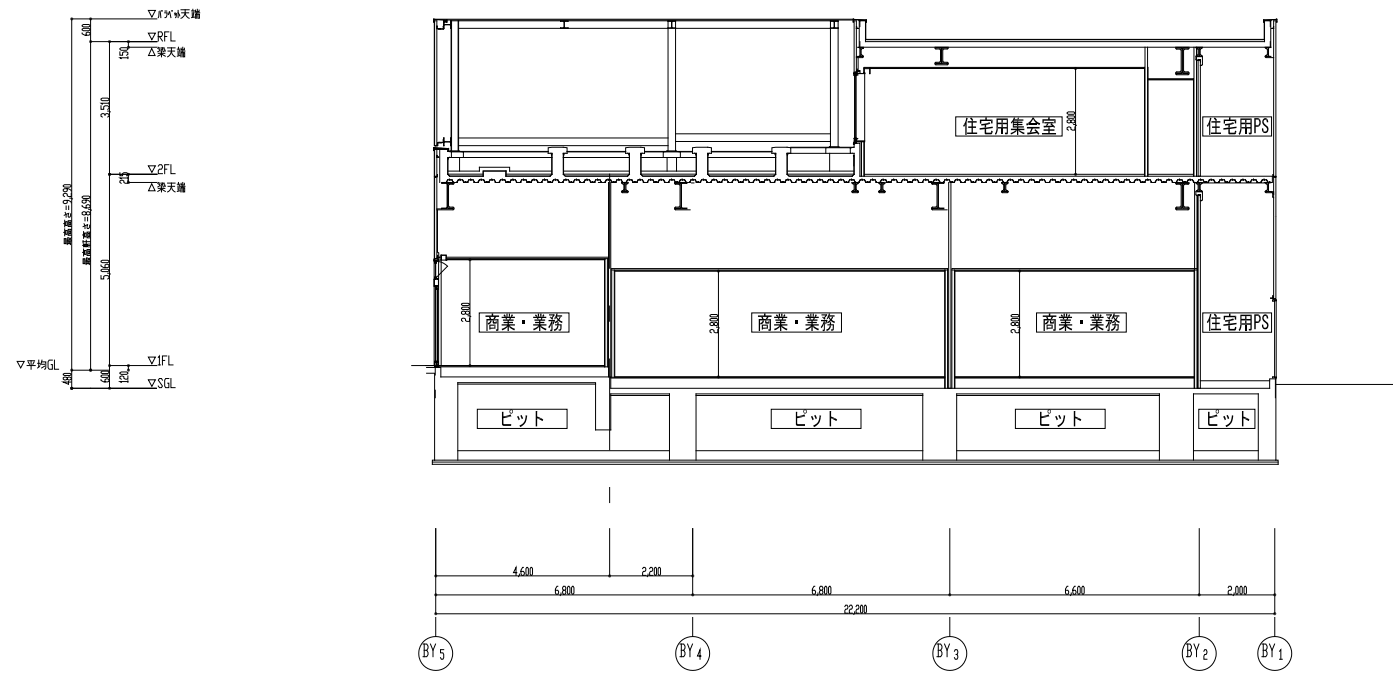

2街区 C-C' 断面図

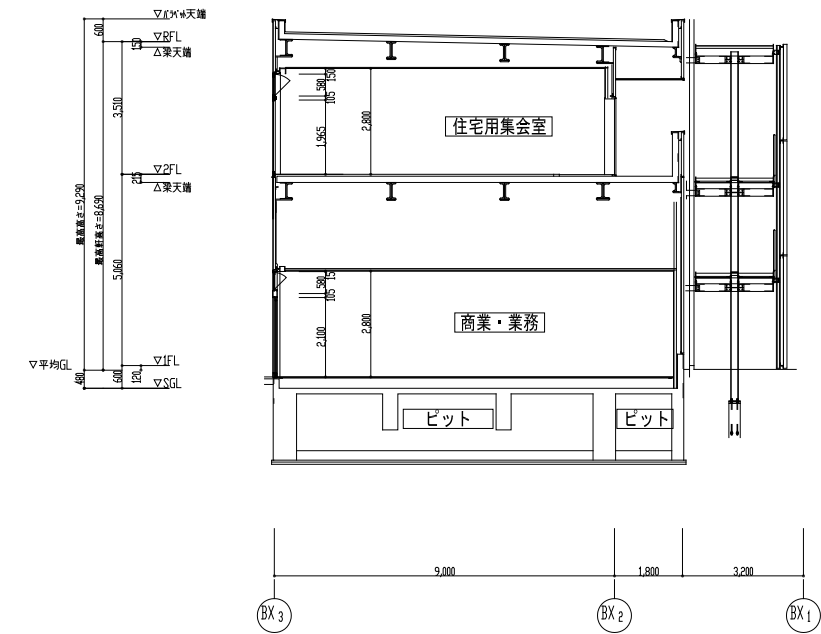

2街区 D-D' 断面図

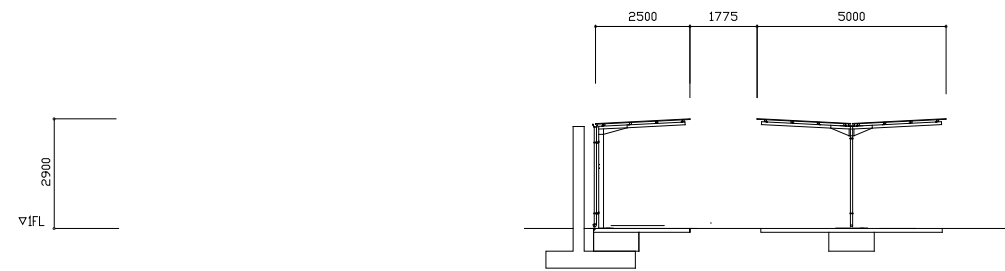

2街区 E-E' 断面図

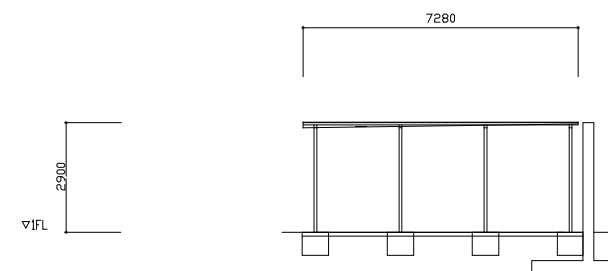

2街区 F-F' 断面図

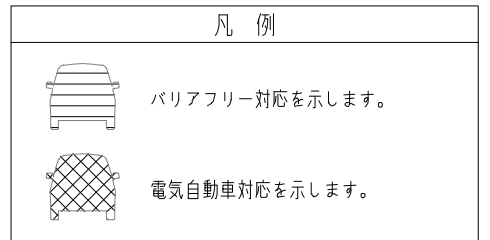
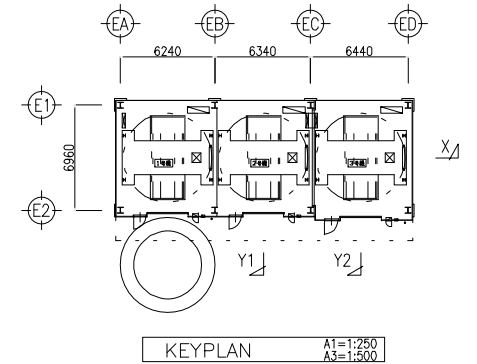
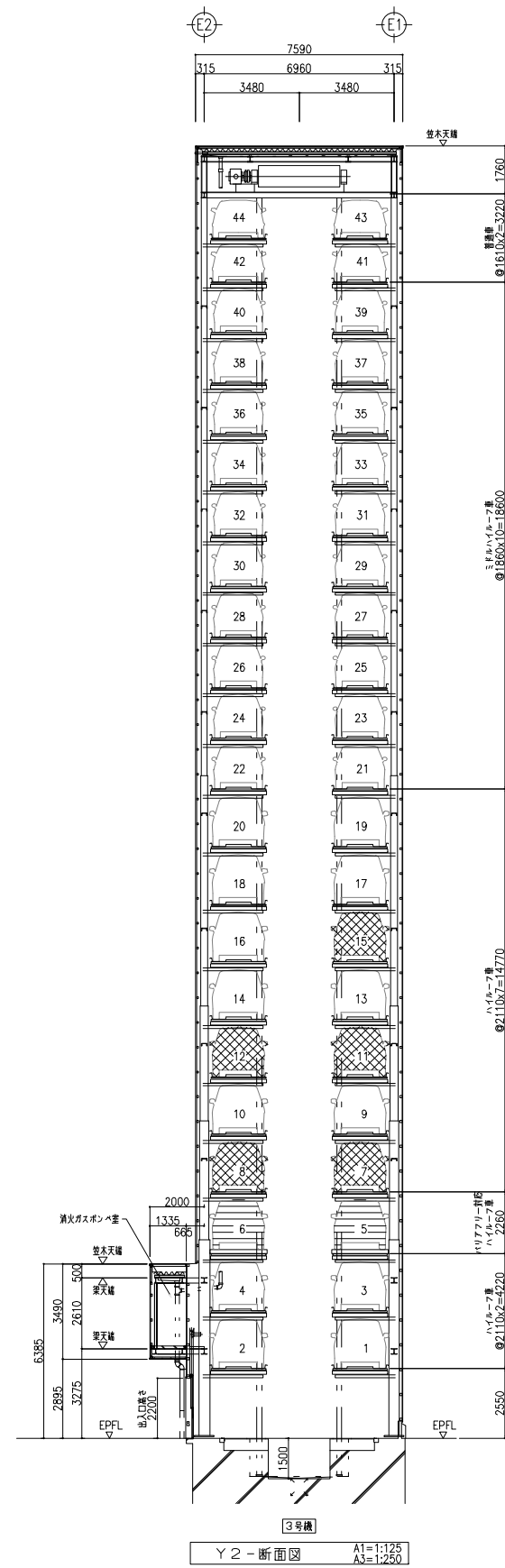
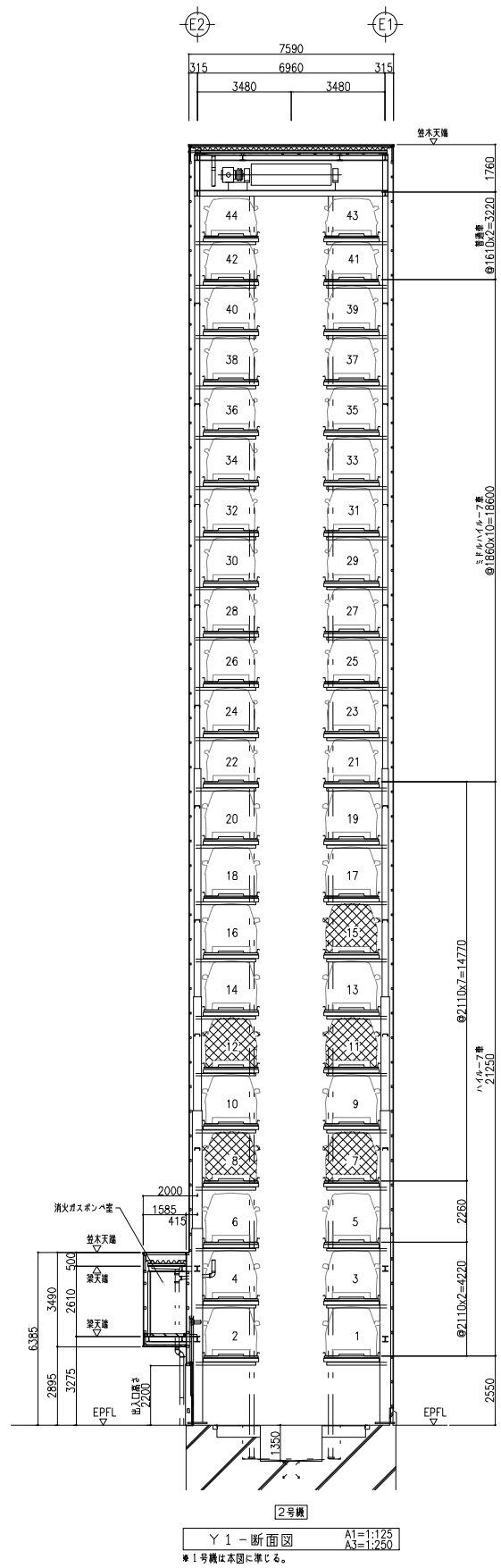
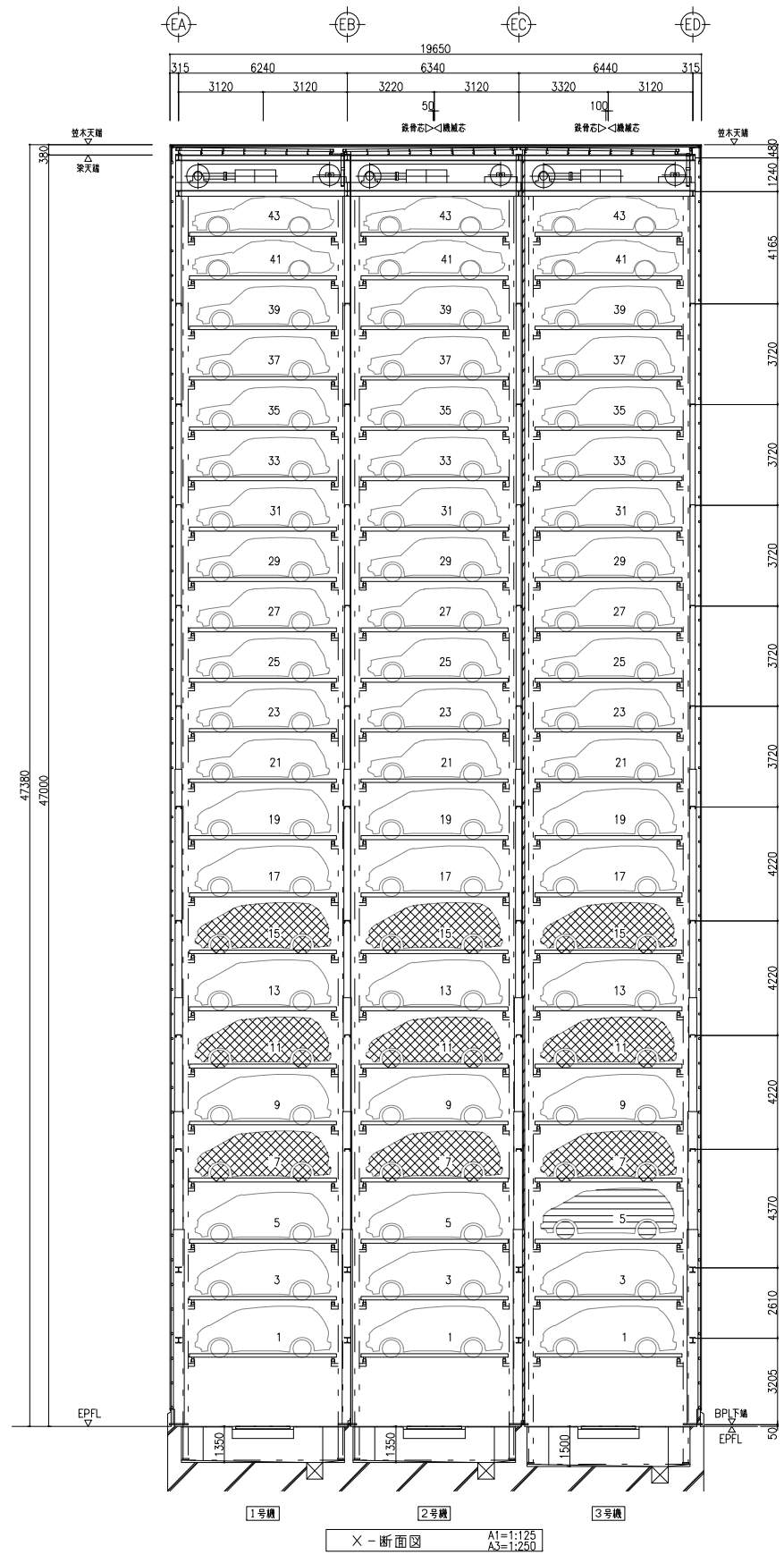

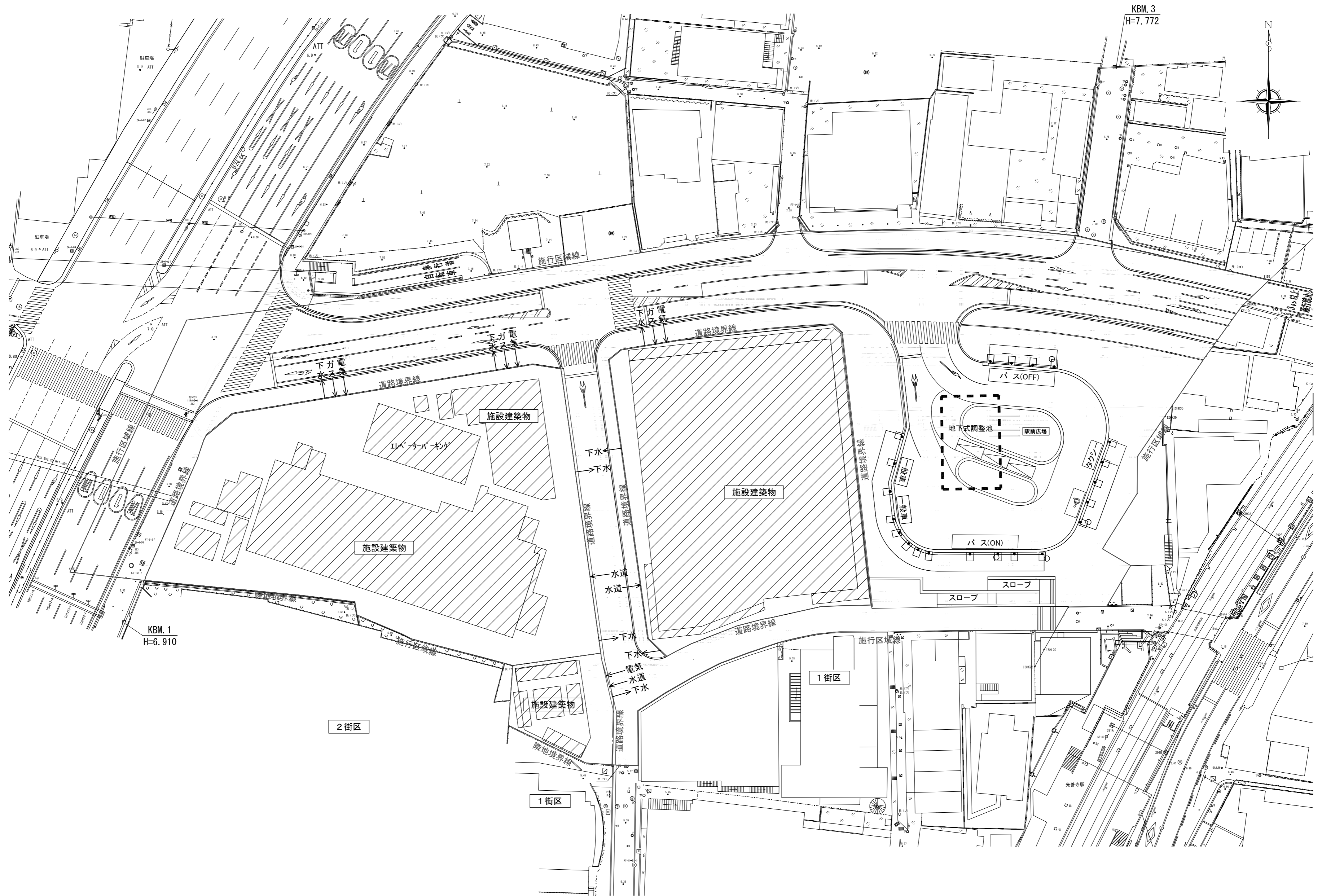

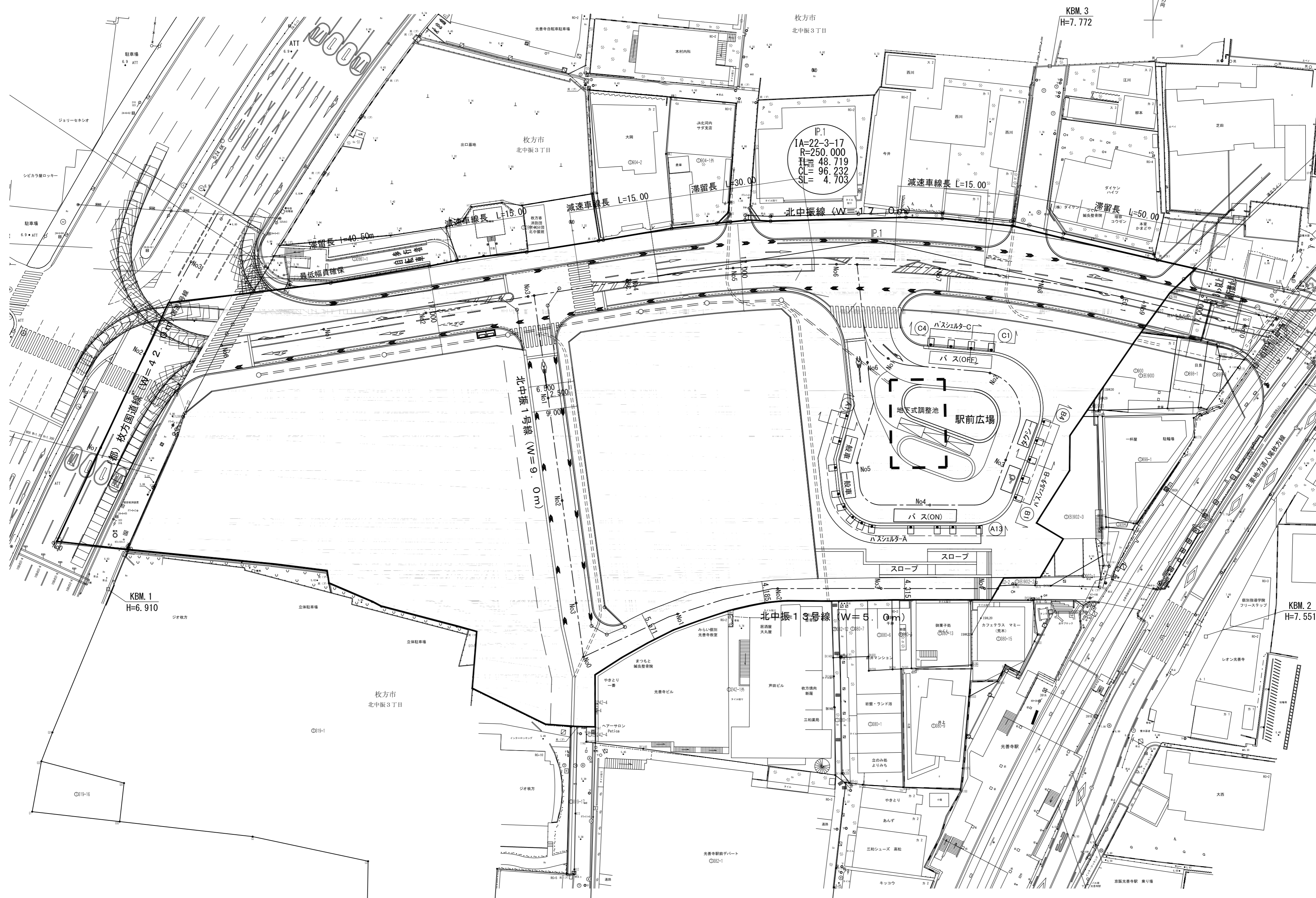

計画縦断図

A1 V=1:200  
A1 H=1:500

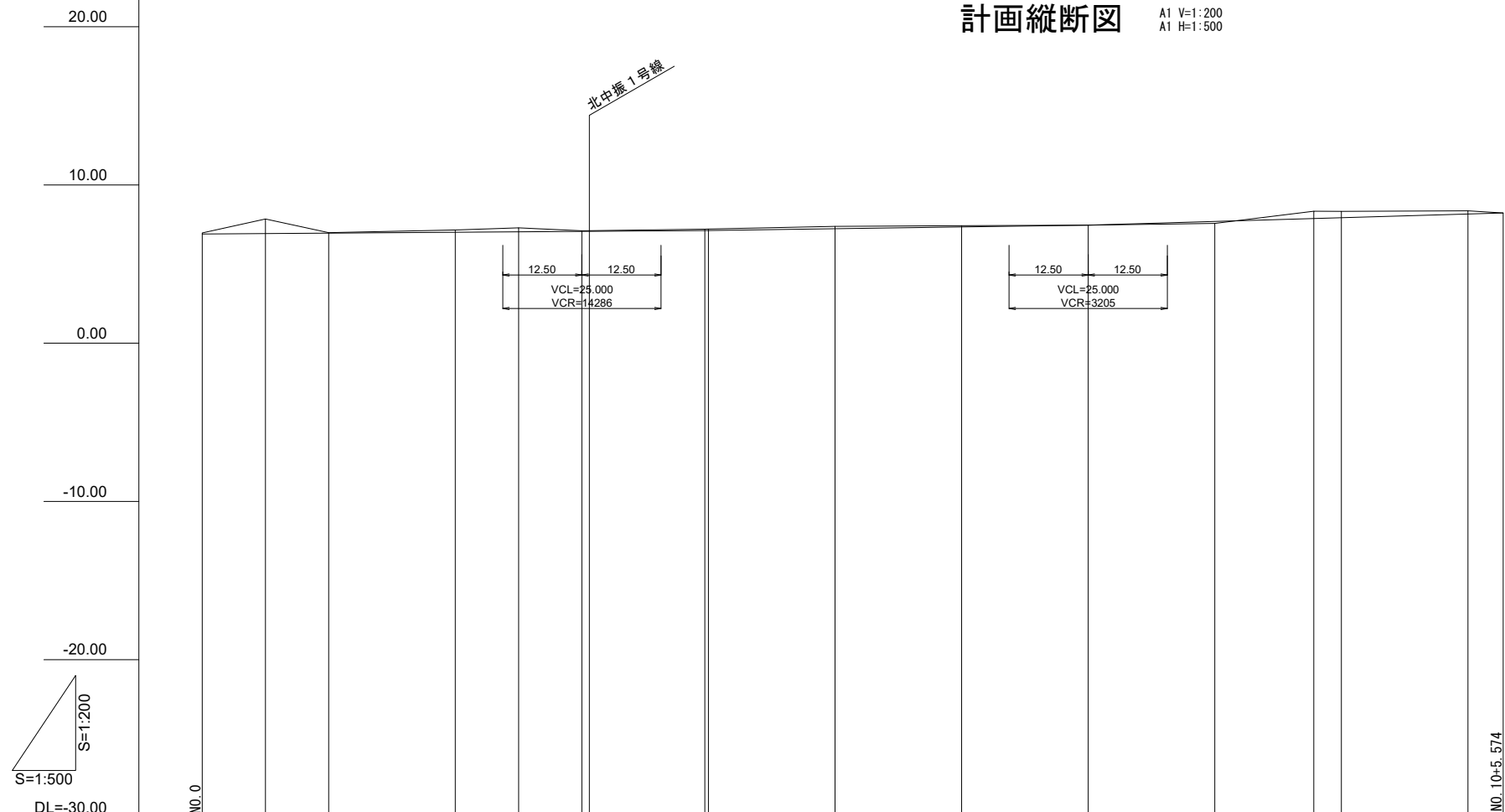

勾配																	
盛土高	0.000, 0.111, 0.000																
切土高	0.230	1.050	0.120	0.170	0.250	0.005	0.009	0.017	0.025	0.110	0.065	0.471	0.408	0.197			
計画高	6.740	6.800	6.860	6.980	7.040	7.095	7.101	7.183	7.185	7.270	7.355	7.464	7.681	7.869	7.922	8.163	8.230
地盤高	6.97	7.85	6.98	7.15	7.29	7.10	7.11	7.20	7.21	7.38	7.42	7.46	7.57	8.34	8.33	8.36	8.23
追加距離	0.000	10.000	20.000	40.000	50.000	60.000	61.183	79.422	80.000	100.000	120.000	140.000	160.000	175.654	180.000	200.000	205.574
単距離	0.000	10.000	10.000	20.000	10.000	10.000	1.183	18.239	0.578	20.000	20.000	20.000	20.000	15.654	4.346	20.000	5.574
測点	NO.0	+10.000	NO.1	NO.2	+10.000	NO.3	+1.183	B.C. 1	NO.4	NO.5	NO.6	NO.7	NO.8	E.C. 1	NO.9	NO.10	+5.574
曲線	IA=22-3-17 R=250.000 CL=96.232 TL=48.719 SL=4.703																
片勾配すり付図																	
拡幅すり付図																	

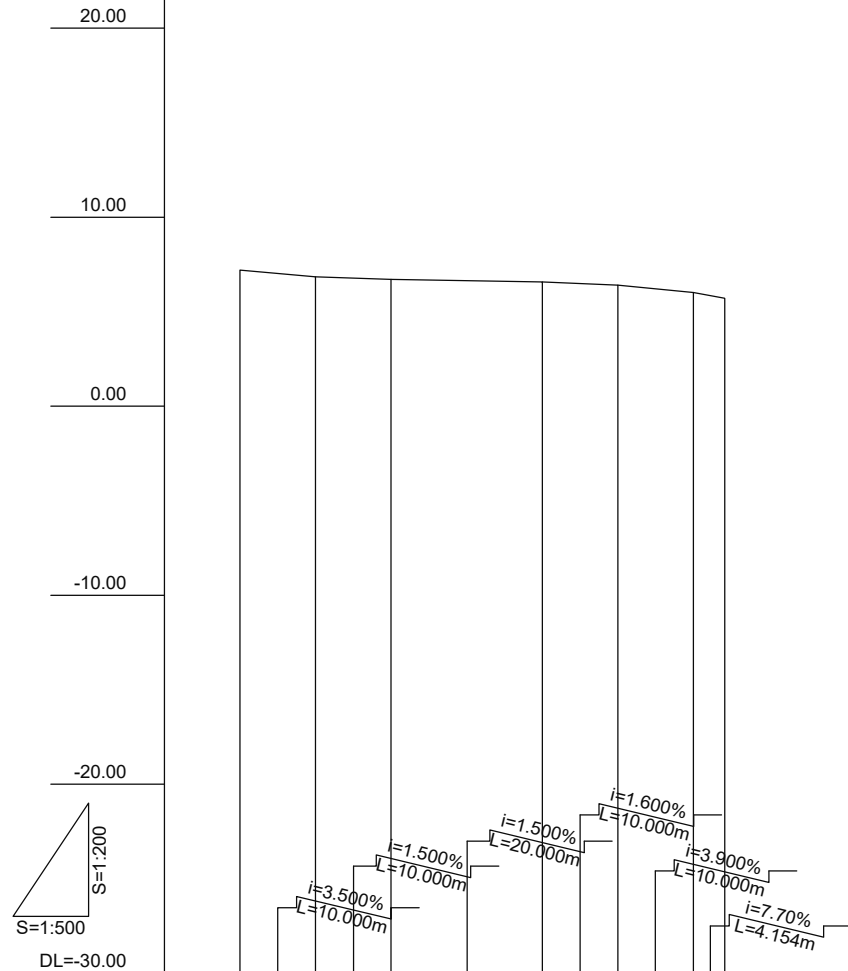

勾配	7.200	6.850	6.700	6.570	6.410	6.020	5.700
盛土高							0.000
切土高							
計画高	7.200	6.850	6.700	6.570	6.410	6.020	5.700
地盤高	7.20	6.85	6.70	6.57	6.41	6.02	5.70
追加距離	0.000	10.000	20.000	40.000	50.000	60.000	64.154
単距離	0.000	10.000	10.000	20.000	10.000	10.000	4.154
測点	NO.0	+10.000	NO.1	NO.2	+10.000	NO.3	+4.154
曲線							
片勾配すり付図							
拡幅すり付図							

枚方国道線(W=42.0m)縦断面図

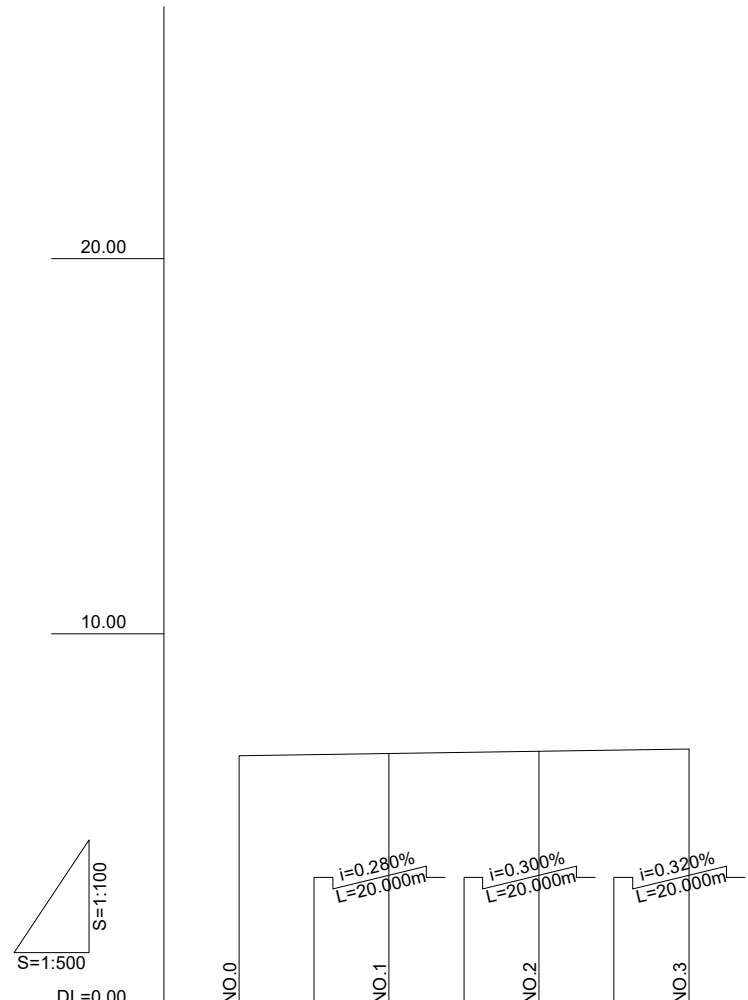

勾配	6.750	6.806	6.866	6.930
盛土高	0.000	0.000	0.000	0.000
切土高				
計画高	6.750	6.806	6.866	6.930
地盤高	6.75	6.81	6.87	6.93
追加距離	0.000	20.000	40.000	60.000
単距離	0.000	20.000	20.000	20.000
測点	NO.0	NO.1	NO.2	NO.3
曲線				
片勾配すり付図				
拡幅すり付図				



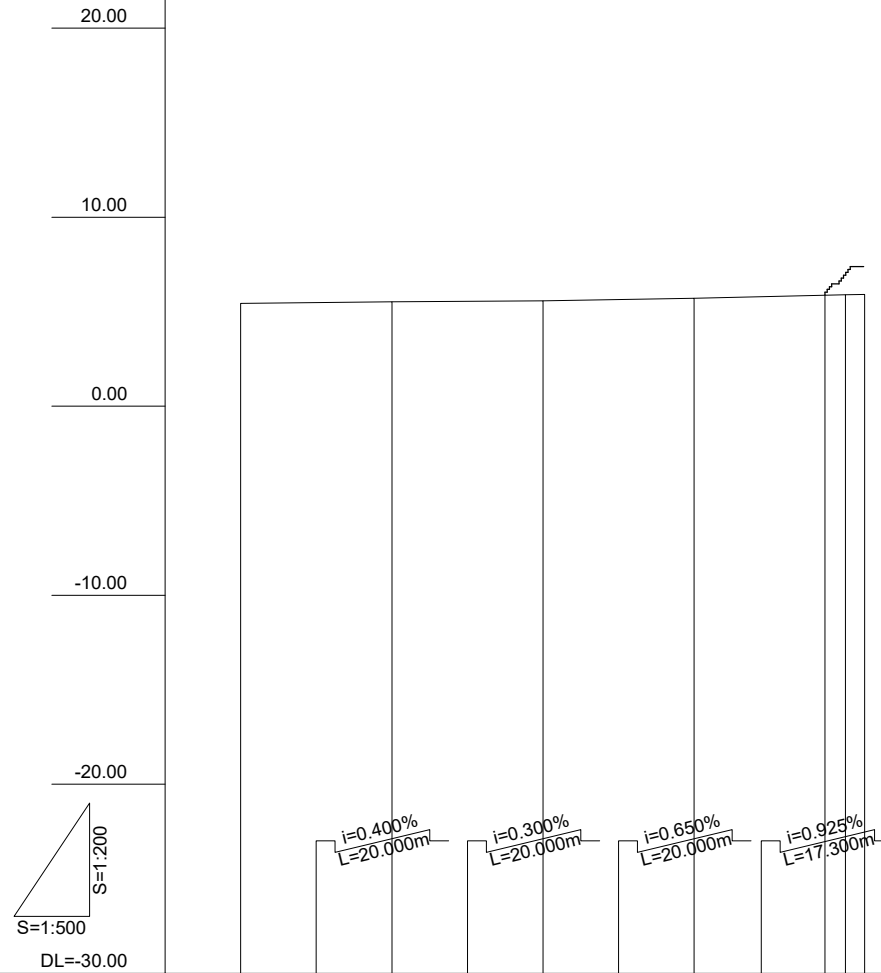

勾配	5.440	5.520	5.580	5.710	5.870
盛土高					
切土高					
計画高	5.440	5.520	5.580	5.710	5.920
地盤高	5.44	5.52	5.58	5.71	5.92 5.90 5.92
追加距離	0.000	20.000	40.000	60.000	77.300 80.000 82.530
単距離	0.000	20.000	20.000	20.000	17.300 20.000 2.530
測点	NO.0	NO.1	NO.2	NO.3	+17.300 NO.4 +2.530
曲線					
片勾配すり付図					
拡幅すり付図					

# 駅前広場道路縦断図

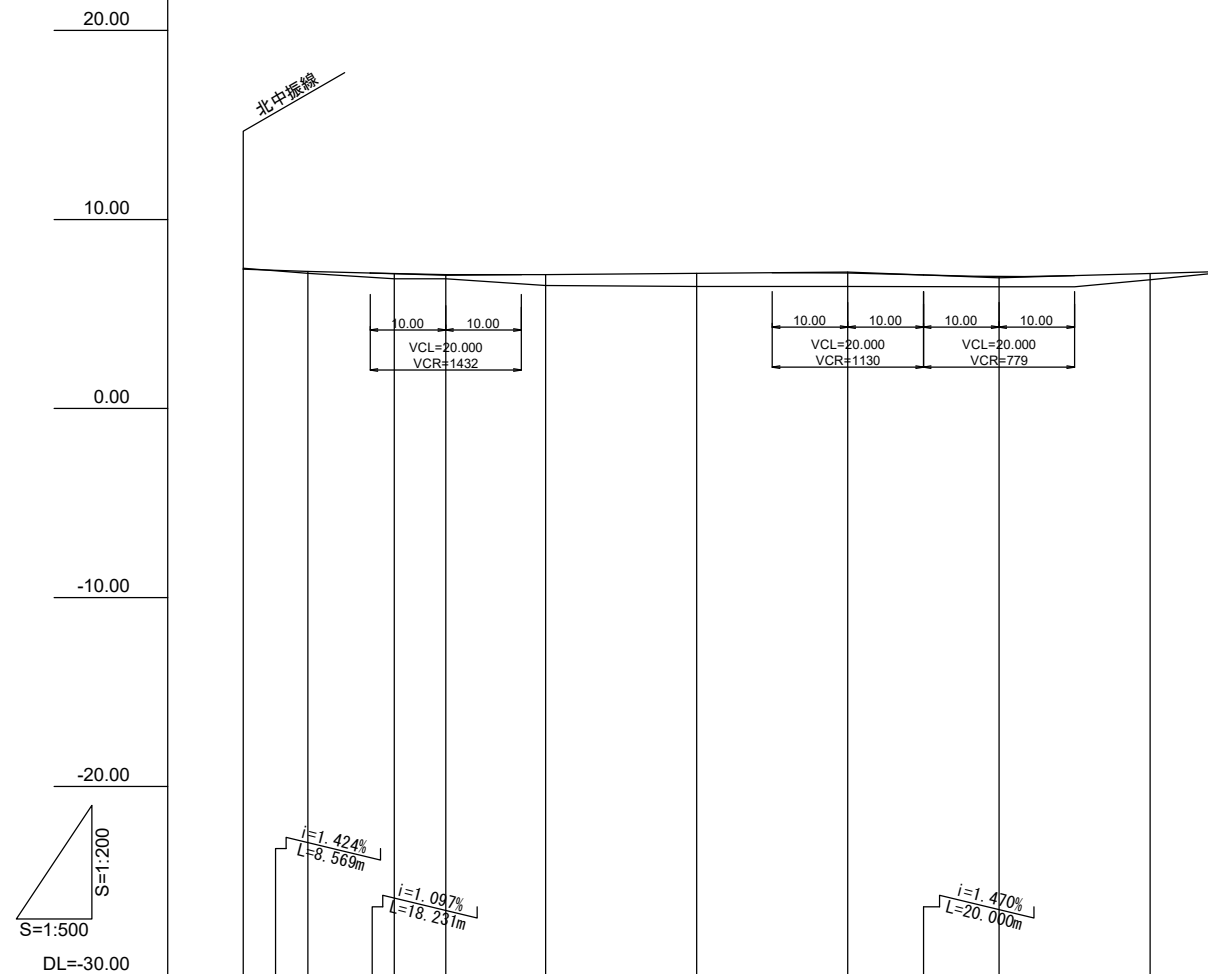

勾配	7.372	7.250	7.050	7.210	6.916	7.227
盛土高	0.100	0.258	0.215	0.580	0.700	0.716
切土高	0.048					
計画高	7.372	7.250	7.128	7.085	7.090	7.150
地盤高	7.42	7.15	6.87	6.87	6.51	6.45
追加距離	0.000	8.569	20.000	26.800	40.000	60.000
単距離	0.000	8.569	11.431	6.800	13.200	20.000
測点	NO.0	+8.569	NO.1	+6.800	NO.2	NO.3
曲線						
片勾配すり付図						
拡幅すり付図						

# 標準横断面図

道路設計条件	
道路規格	第4種 第2級
設計速度	V=30km/hr
交通量区分	
設計CBR	

北中振線 (W=17.0m)

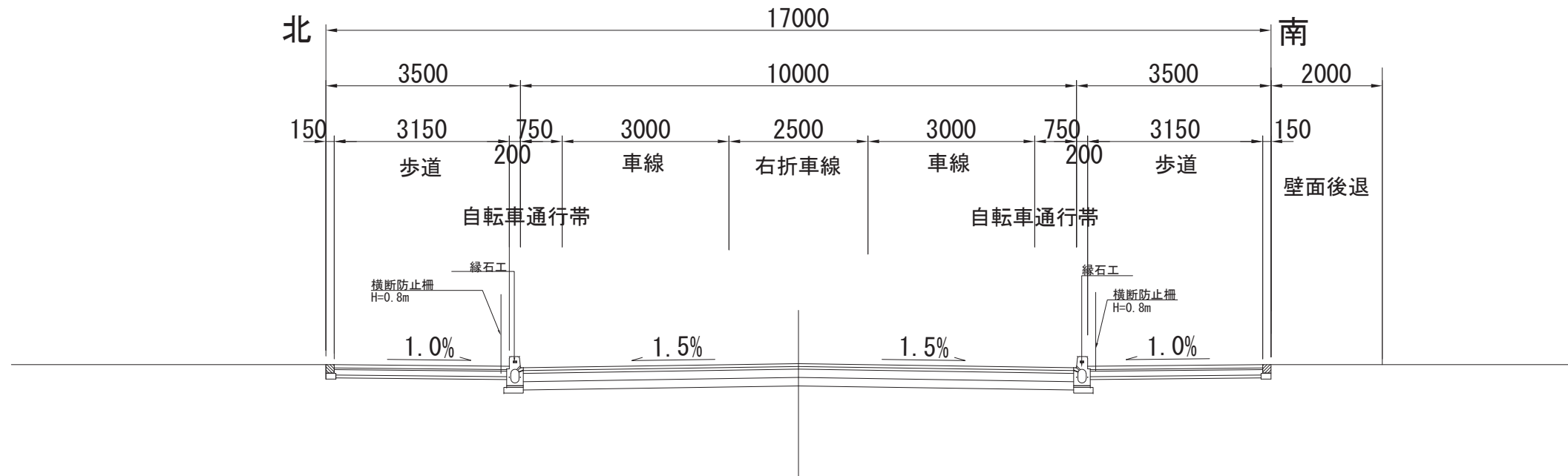

北中振1号線 (W=9.0m)

道路設計条件	
道路規格	第4種 第4級
設計速度	V=30km/hr
交通量区分	
設計CBR	

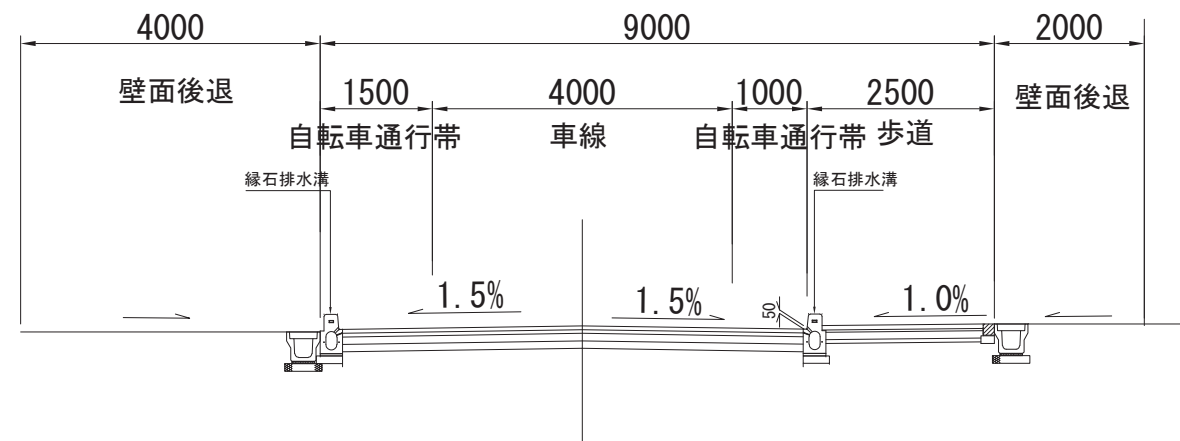

北中振13号線 (W=5.0m)

道路設計条件	
道路規格	第4種 第4級
設計速度	V=30km/hr
交通量区分	
設計CBR	

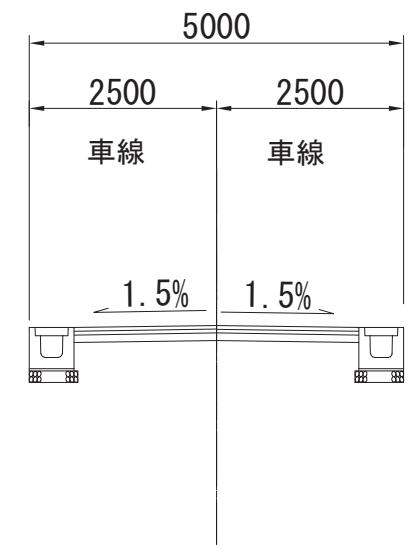

# 標準横断図

## 駅前広場

### 南北断面

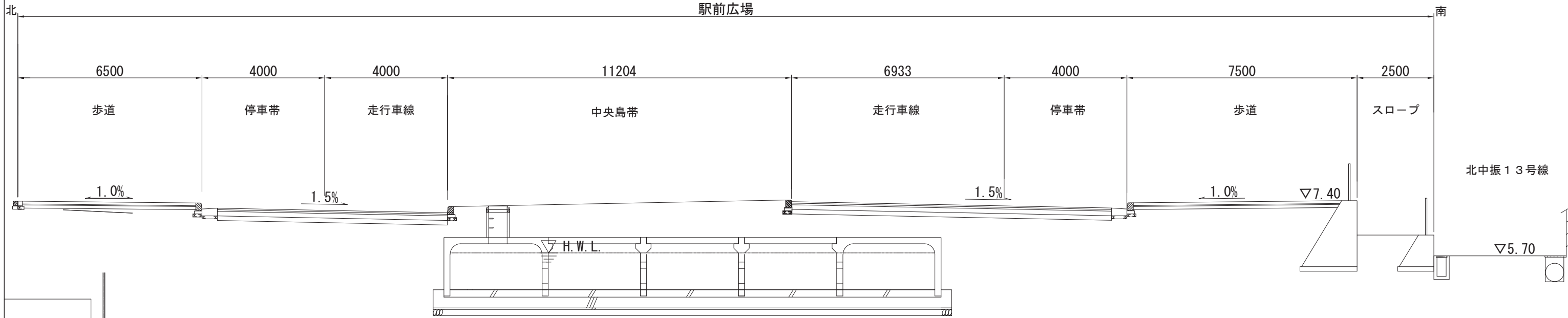

### 東西断面

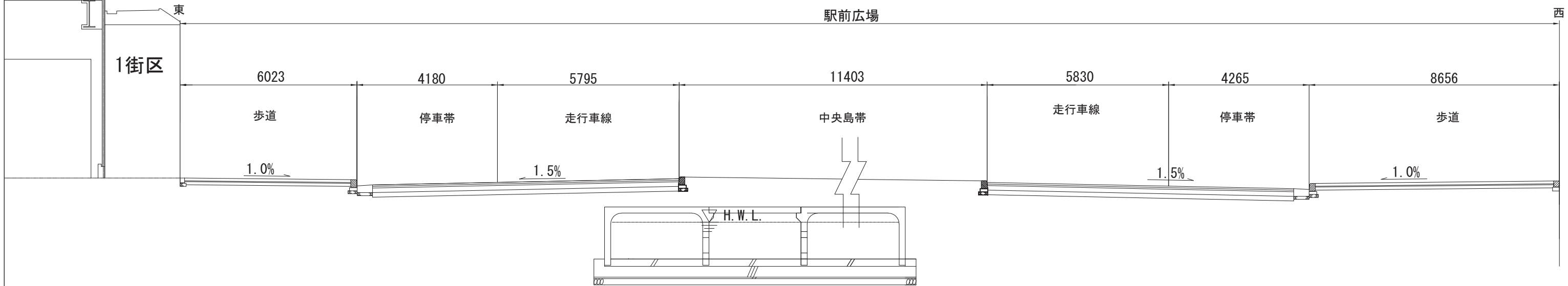

# 標準横断図

(都) 枚方国道線 (W = 42.0 m)

